

AJ977XF

NavtechGPS
+1-703-256-8900 or 800-628-0885
info@NavtechGPS.com
www.NavtechGPS.com



TALLYSMAN[®]
A CALIAN[®] COMPANY

AJ977XF - AntiJam Triple Band GNSS Antenna

Frequency Coverage: GPS/QZSS-L1/L2/L5, GLONASS-G1/G2/G3, Galileo-E1/E5a/E5b, BeiDou-B1/B2/B2a + NavIC-L5

Overview

The AJ977XF supports GPS/QZSS L1/L2/L5, GLONASS-G1/G2/G3, Galileo-E1/E5a/E5b, BeiDou-B1/B2/B2a, and NavIC-L5 frequency bands, including the satellite-based augmentation system (SBAS) available in the region of operation [WAAS (North America), EGNOS (Europe), MSAS (Japan), or GAGAN (India)].

The AJ977XF Anti Jam antenna is designed to mitigate interference and jamming signals broadcast from near ground-based transmitters. The radiation pattern of the Low Elevation Angle Nulling Antenna (LEANA) provides 20 dB (Typical) wideband suppression for all GNSS band signals received at an elevation angle of 0° through to approximately 15°. This level of attenuation will mitigate a 600 Watt jamming signal broadcast at an elevation angle of 10°, 100m or greater away from the AJ977XF antenna. The combination of Tallysman's low elevation angle nulling radiation pattern, and eXtended Filtering (deep filters and high IP3 (prevents saturation in the presence of noise)) technologies provides a one two punch to jamming and radio frequency noise. At the same time the AJ977XF's radiation pattern above 20° elevation angle provides excellent gain and a phase center that supports accurate and precise positioning.

Tallysman's eXtended Filter (XF) antenna technology has been designed to mitigate out-of-band signals and prevent GNSS antenna saturation. In North America, Ligado signals at 1525 - 1536 MHz can especially impact GNSS antennas that support space-based L-band correction services (1539 - 1559 MHz). New LTE signals in Europe [Band 32 (1452 - 1496 MHz)] and Japan [Bands 11 and 21 (1476 - 1511 MHz)] have also been observed to interfere with GNSS signals. In addition, Inmarsat satellite communication (uplink: 1626.5 - 1660.5 MHz) can also affect GNSS signals. Tallysman's custom XF filtering mitigates all existing signals and new Ligado and LTE signals, enabling the antennas and attached GNSS receivers to perform optimally.

The Tallysman AJ977XF antenna is ideal of all mission critical positioning, navigation and timing applications.



Applications

- Mission-critical global positioning
- Timing applications
- Law enforcement and public safety

Features

- Great axial ratio (1.0 dB typ.)
- Low LNA noise (2.5 dB typ.)
- High-rejection XF Filtering
- High-gain LNA (40 dB typ.)
- Low current (26 mA typ.)
- Wide voltage input range (2.5 to 16 VDC)
- ESD circuit protection (15 kV)
- IP67 weather-proof housing
- RoHS and REACH compliant
- 20dB attenuation at 0-15° Elevation.

Benefits

- Operates under ground-based jamming
- Circular polarisation throughout the full bandwidth
- Superior multipath signal rejection
- Excellent signal-to-noise ratio
- Excellent out-of-band signal rejection
- Increased system accuracy
- Ideal for noisy RF environments



Contact NavtechGPS for product details. www.NavtechGPS.com
+1-703-256-8900 • 800-628-0885 • info@navtechgps.com

AJ977XF - AntiJam Triple Band GNSS Antenna

Frequency Coverage: GPS/QZSS-L1/L2/L5, GLONASS-G1/G2/G3, Galileo-E1/E5a/E5b, BeiDou-B1/B2/B2a + NavIC-L5

Antenna

Technology Triple-frequency, RHCP quadrifilar helix

		Gain dBic typ. at Zenith	Axial Ratio dB at Zenith
GNSS			
GPS / QZSS	L1	2.5	≤ 1.0
	L2	3.7	≤ 1.0
	L5	1.9	≤ 1.0
GLONASS	G1	1.8	≤ 1.0
	G2	3.0	≤ 1.0
	G3	3.0	≤ 1.0
Galileo	E1	2.5	≤ 1.0
	E5A	1.9	≤ 1.0
	E5B	3.0	≤ 1.0
	E6	-	-
BeiDou	B1	2.5	≤ 1.0
	B2	3.3	≤ 1.0
	B2a	1.9	≤ 1.0
	B3	-	-
IRNSS / NavIC	L5	1.9	≤ 1.0
QZSS	L6	-	-
L-Band Services (1525 MHz - 1559 MHz)		-	-
Satellite Communications			
Iridium		-	-
Globalstar		-	-
Other			
Axial Ratio at 10°		-	Efficiency
PC Variation		-	PCO

Mechanicals

Size 90.0 mm (dia.) x 180 mm (h.)
 Weight 245 g
 Radome Radome: EXL9330 , Base: Zamak White Metal
 Mount Though-hole
 Available Connectors TNC Female

Environmental

Operating Temperature -40 °C to +85 °C
 Storage Temperature -50 °C to +95 °C
 Vibration 0
 Shock 0
 Salt Fog 0
 IP Rating IP67
 Compliance IPC-A-610, FCC, RED / CE Mark, RoHS, REACH

Warranty:

Parts and Labour 3-year standard warranty

Low Noise Amplifier (LNA) - Measured at 3V and 25°C

Frequency Bandwidth	Out of Band Rejection
Lower Band	1164 -1254 MHz >85dB@<1100 MHz >82dB@>1300 MHz >90dB@<1325 MHz
L-Band - Correction Services	-
Upper Band	1559 - 1606 MHz > 75 dB @ < 1526 MHz > 47 dB @ < 1536 MHz > 35 dB @ > 1626 MHz

Architecture Pre-filter → LNA stage 1 → another stage
 Gain 40 dB typ.
 Noise Figure 2.5 dB typ.
 VSWR < 1.5:1 typ. | 1.8:1 max.
 Supply Voltage Range 2.5 to 16 VDC
 Supply Current 62 mA typ.
 ESD Circuit Protection 15 kV air discharge
 P 1dB Output 15 dBm @ L1 | 15 dBm @ L2/L5
 Group Delay 10 ns @ L1 | 4 ns @ L2 | 11 ns @ L5

Mechanical Diagram

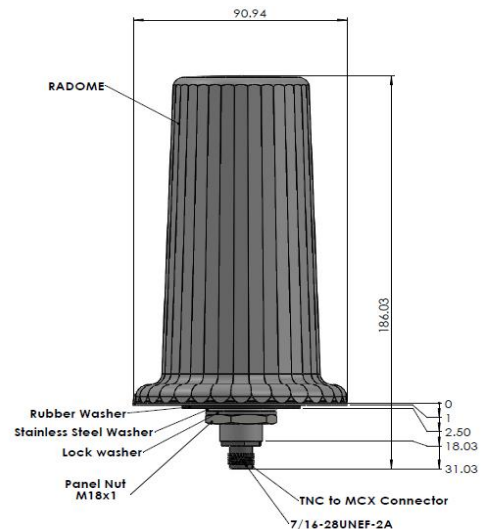

Ordering Information

Part Number **33-AJ977XF**



Contact NavtechGPS for product details. www.NavtechGPS.com
 +1-703-256-8900 • 800-628-0885 • info@navtechgps.com