



Contact NavtechGPS for product details. [www.NavtechGPS.com](http://www.NavtechGPS.com)  
+1-703-256-8900 • 800-628-0885 • [info@navtechgps.com](mailto:info@navtechgps.com)

### KEY FEATURES

Support for GPS L1, GLONASS L1,  
GPS L2, and GLONASS L2

Low-profile Fuselage/Bulkhead Mounting

Sub-centimeter phase center  
repeatability

Small rugged package ideal for vehicle  
or man portable applications

### HIGH PERFORMANCE DUAL FREQUENCY GNSS SUPPORT

The Trimble AV34 GNSS Antenna has been designed to support high accuracy aerial, land and marine applications in one compact design. The rugged 4 hole bulkhead mounting allows the antenna to be used in the most rugged of environments.

#### GNSS SUPPORT

The Trimble AV34 GNSS antenna offers support for both GPS and GLONASS L1/L2 signals. These are the optimum set of signals for your high accuracy RTK receiver. Dual frequency allows for faster initialization and dual constellation improves the number of satellites available for positioning, especially in obstructed environments.

#### ROBUST, LOW-MULTIPATH GPS ANTENNA

The antenna resists unwanted signal interference or multipath, which can cause inaccurate measurements. Multipath is caused by signals being reflected from surfaces such as the ground, surrounding trees, or buildings.

#### FLEXIBILITY

The antenna is an aviation type of design. The bulkhead mounting ensures only the rugged radome is exposed to the elements. This is an ideal design for customers building machine control systems. The antenna can be mounted flush with the vehicle surface or on the top of a pole mount. The TNC connector is located on the underside of the unit ensuring the attached cable is also protected from the environment.



Trimble AV34 Antenna

# TRIMBLE AV34 GNSS ANTENNA

## PERFORMANCE

- L1 Band GNSS Frequency tracking Including:
  - GPS: L1
  - GLONASS: L1
  - SBAS: WAAS, EGNOS, QZSS, Gagan, MSAS
- L2 Band GNSS Frequency tracking Including:
  - GPS: L2
  - GLONASS: L2
- Quality signal tracking
- TNCF female signal connector
- Small cross-sectional area to reduce wind loading
- Low voltage, low power consumption
- Integral low noise amplifier
- Powered by GNSS receiver via coaxial cable
- High gain for reliable tracking in difficult environments
- 4 recessed bulkhead mounting holes
- Rugged radome designed for machine environments

## ELECTRICAL

Frequencies ..... 1565–1607 MHz  
 1217–1260 MHz  
 Signal gain ..... 43 dB  
 Voltage ..... 4.5 V DC to 18 V DC  
 Polarization ..... Right Hand Circular  
 Axial Ratio ..... 3 dB Max @ boresight  
 Amplifier ..... Noise Figure : 2.5 dB  
 Impedance : 50 Ohms  
 VSWR : ≤ 2.0:1

## HARDWARE

Dimensions ..... 8.9 cm diameter, 2.1 cm height  
 (3.5" diameter, 0.84" height)  
 Weight ..... 0.213 Kg (0.47 lb)  
 Operating Temperature ..... -55 °C to +85 °C (-67 °F to +185 °F)  
 Altitude ..... ≤ 16,764 m (55,000 ft)  
 Finish ..... UV resistant, high impact thermoplastic white radome  
 with aluminum base  
 Compliance ..... ROHS

## ENVIRONMENTAL QUALIFICATIONS

CONDITIONS	DO-160D SECTION	STRING CATEGORY	DESCRIPTION
Temperature Variation	5	A	-55°C to +85°C, 10°/min, 2 cycles
Humidity	–	Method 507.4	MIL-STD-810-F
Shock	–	Method 516.5	MIL-STD-818-F Procedure II
Vibration	–	Method 514.5C-3	MIL-STD-810-F, Section 514.5-CVII

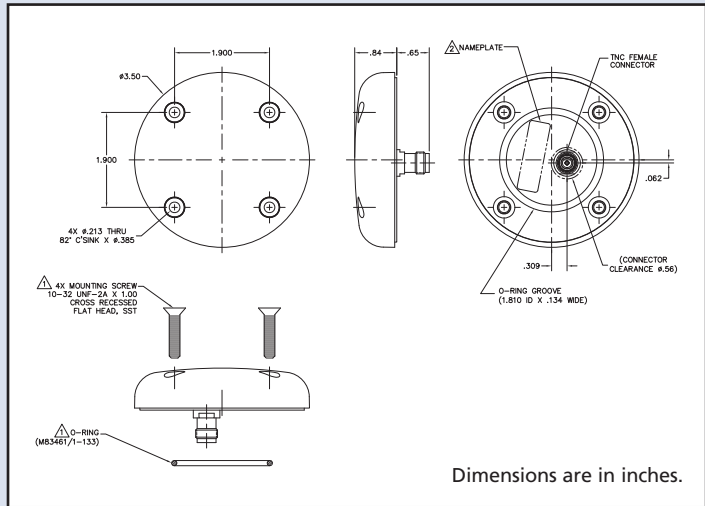

Antenna shown with optional bracket. Bracket allows for mounting on single center 5/8 bolt or four perimeter bolts.

Specifications subject to change without notice.

© 2012, Trimble Navigation Limited. All rights reserved. Trimble and the Globe & Triangle logo are trademarks of Trimble Navigation Limited, registered in the United States and in other countries. All other trademarks are the property of their respective owners. PN 022510-108 (02/12)



www.trimble.com/gnss-inertial

**AMERICAS & ASIA-PACIFIC**  
**TRIMBLE NAVIGATION LIMITED**  
**Integrated Technologies**  
 510 DeGuigne Drive  
 Sunnyvale, CA 94085  
 USA  
 +1-408-481-8070 Phone  
 +1-408-481-8984 Fax  
 Email: sales-intech@trimble.com

**EUROPE & MIDDLE EAST**  
**TRIMBLE GERMANY GmbH**  
**Integrated Technologies**  
 Am Prime Parc  
 1165479 Raunheim,  
 Germany  
 Phone +49 (6142) 177-2135  
 Fax +49 (6142) 177-2136  
 emeasales-intech@trimble.com

**CHINA**  
**TRIMBLE NAVIGATION LIMITED**  
**Integrated Technologies**  
 311 Fute (M) Road, 3/F  
 Wai Gaoqiao Free Trade Zone  
 Pudong, Shanghai 200131  
 China  
 Email: chinasales-intech@trimble.com

**RUSSIA**  
**TRIMBLE NAVIGATION LIMITED**  
**Integrated Technologies**  
 Tel: +7 495 5041081  
 Email: rusales-intech@trimble.com