

OEM7

DEVELOPMENT KIT GUIDE

GM-14915145 Rev 2 July 2016

The OEM7 Development Kit (Dev Kit) provides a convenient way to access OEM7™ input and output signals. The Dev Kit alone is used with NovAtel's OEM7600/7700 receiver cards. To use the Dev Kit with NovAtel's OEM719/729 receiver cards, the optional Interposer Card Kit is required.

Box Contents

In addition to this Guide, the following is provided with your OEM7 Development Kit:

- OEM7 Development Board (NovAtel Part #01019417)
- One BNC-MMCX cable assembly (NovAtel Part #01019431)
- One TNC-MMBX cable assembly (NovAtel Part #01019599)
- Dev Kit power assembly cable (NovAtel Part #01019538)
- 2 m USB cable type A to micro B (NovAtel Part #60723119)
- 1.8 m null modem cable (NovAtel Part #01017658, may contain DEHP), DB-9 female/female to connect to COMs 1, 2 or 3. User provided cables for COM1-RS422, CAN0 and CAN1 connection, as necessary.
- Four adhesive rubber feet (NovAtel Part #28325059)
- Four M3X0.5X10 mm Standoffs (NovAtel Part #28423237)
- Six M3x0.5x6 mm Philips Screws (NovAtel Part #35000306)
- Two 3 mm Spacers (NovAtel Part #28423235)
- Two M2x8 Socket Head Caps (NovAtel Part #28523067)

Optional Interposer Card Content

- OEM7 Interposer board (NovAtel Part #01019416) for use with (OEM729R, OEM729 and OEM719B receiver cards)
- One TNC-MCX cable assembly (NovAtel Part #01019429)
- One TNC-MMCX cable assembly (NovAtel Part #01019430)
- Four M3x0.5x14 mm Hex Standoffs (NovAtel Part #28423059)
- Five M3X0.5X10 mm Standoffs (NovAtel Part #28423237)
- Six M3x0.5x12 mm Hex Standoffs (NovAtel Part #28423222)
- Four M3X0.5X8 mm Standoffs (NovAtel Part #28423231)
- Five M3x0.5x6 mm Philips Screw (NovAtel Part #35000306)

Additional Equipment Required

Depending on the application, some or all of the following will be required:

- OEM7 series receiver card
- A Microsoft Windows-based computing device with a RS-232 DB-9, USB port or 10/100BASE-T port
- A +9 VDC to 36 VDC power supply, capable of supplying at least 10 W
- A quality antenna, such as NovAtel's GNSS-500 or GPS-700 Series. Refer to our web site: www.novatel.com/products/gnss-antennas
- A 50 ohm coaxial cable with a male TNC connector at the Dev Kit end, for connecting to the ANT port
- If necessary, a 50 ohm coaxial cable with a male BNC connector at the Dev Kit end, for connecting to an EXT OSC port (refer to **External Oscillator** and **Mounting the Coaxial Cable in the Bracket** sections on the other side of this sheet)
- An RJ-45 Ethernet cable

See other side of this sheet for details on these ports and button

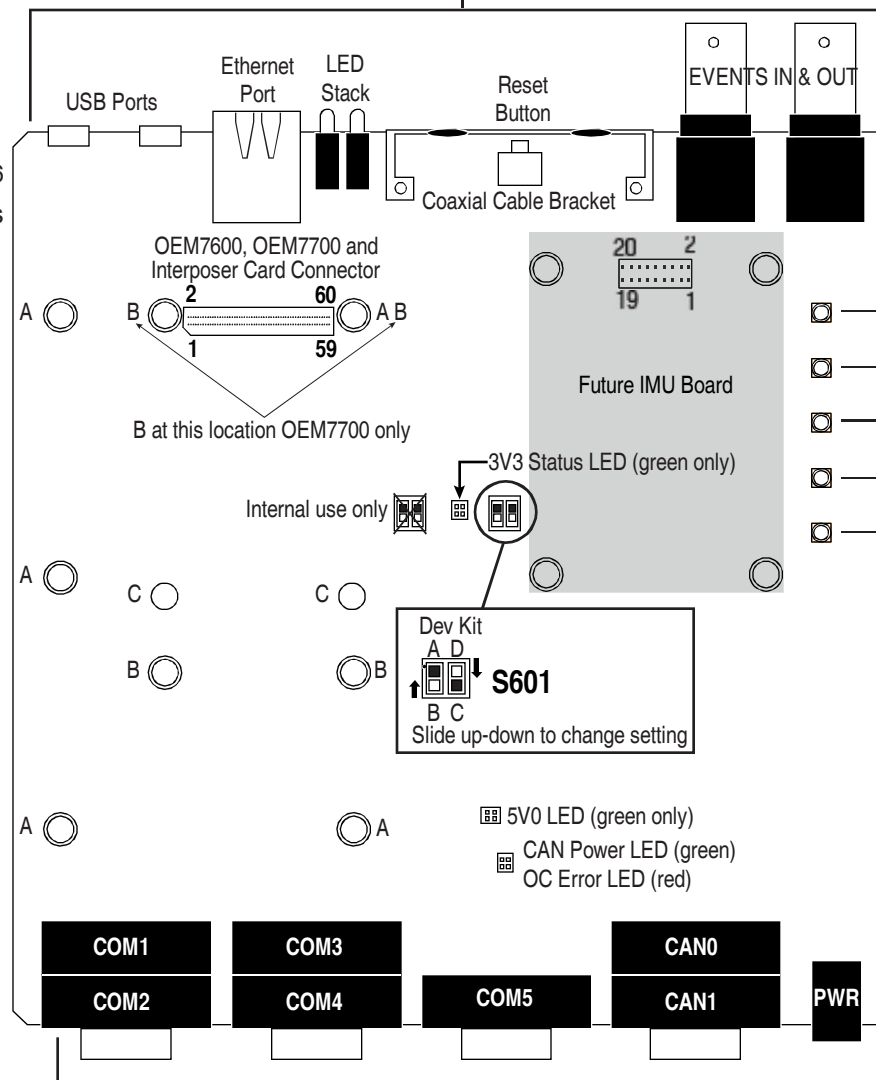

See other side of this sheet for details on these ports and button

Questions or Comments

Contact NovAtel Customer Support to obtain copies of the Dev Kit BOM, schematics and assembly drawings. The OEM7 Dev Kit is not intended to be used as a reference design for implementation in end applications. Original component manufacturer design recommendations should be sought before incorporating any components used on the Dev Kit into an end application design. If you have any questions or comments regarding your OEM7 Development Kit, please contact NovAtel using one of these methods:

Email: support@novatel.com

Web: www.novatel.com

Phone: 1-800-NOVATEL (U.S. & Canada)
403-295-4500 (International)

Fax: 403-295-4501

NovAtel is a registered trademark of NovAtel Inc.
OEM7 is a trademark of NovAtel Inc.
Content subject to change without notice.
OEM7 Development Kit

©Copyright 2007-2016 NovAtel Inc. All rights reserved.
Printed in Canada on recycled paper. Recyclable.



Proper ESD precautions should be followed when handling boards.

- MMCX Straight Connectors
- TIMEMARK
- EVENT_IN3
- EVENT_IN4
- EVENT_OUT3
- EVENT_OUT4

Hardware Use

OEM Card	Size	# Included	NovAtel Standoff Part #	Connect Card to...	Standoff Insertion Position
Interposer Board	10 mm	5	28423237	Dev Board	A
OEM7700		4			B
OEM7600	3 mm	2	28423235		C
OEM729	14 mm	4	28423059	Interposer Board	D
OEM729R	12 mm	6	28423222	Interposer Board	E
OEM719 OEM719A OEM719B	8 mm	4	28423231	Interposer Board	F
Interposer Board to Dev Board	M3 Screws	5	35000306		
IMU (future use)	6 mm	4	28423223	Dev Board	Future use

Insert standoffs into appropriate holes for card(s) used. Secure using screws.

When using standoffs with receiver cards or mounting directly to Dev Board, attach the MCX, MMCX or MBX connector as required BEFORE securing the boards with the standoffs and screws.

OEM7600/7700- Development Board Switch Settings

Switch Label	Position	Function
S601	A=422 B=232	Select COM1 and COM2 232 or 422 mode
	C=COM5 TXD/RXD D=COM2 CTS/RTS	Either activate COM5 or enable COM2 flow control
S301	Internal use only	

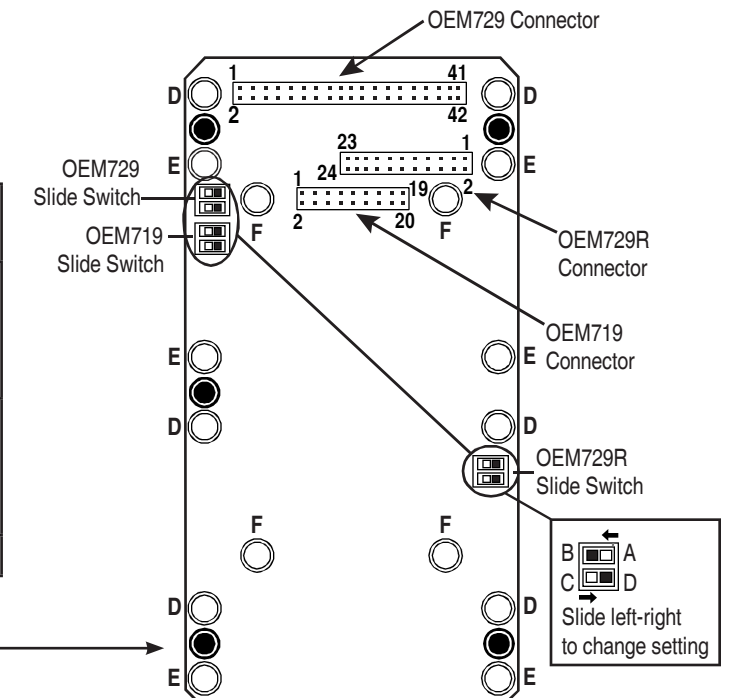

OEM719/729- Optional Interposer Card Switch Settings

Switch Label	Signal	OEM729	OEM719
S101	729 COM1 422/232 (U201)	D=729 COM1 in 422 mode C=729 COM1 in 232 mode	n/a
S201	719 CAN MUX (U301)	n/a	B=CAN0 A=EVENT_OUT2 & EVENT_IN2
S301	729 COM3 MUX (U303)	A=GPIO & EVENT_IN2 B=COM3	n/a
S301	719 COM3/USB MUX (U304, U302)	n/a	C=COM3 D=USB & EVENT_IN1

Coaxial Cable Assembly (for ANT/OSC/EVENTS)

Connect this end as indicated below		Connect this end as indicated below		
Attach to Antenna port of receiver card	MCX	OEM719/OEM719A 	TNC	GNSS Antenna
		#01019429		
	MMCX	OEM729/OEM729R/OEM7600 		
		#01019430		
	MMBX	OEM7700/OEM719B 		
		#01019599		
Attach to External Oscillator on receiver card or Event lines on Dev Board	MMCX	OEM729/OEM729R/Dev Board 	BNC	OSC (External Oscillator) EVENTS
		#01019431		

Always connect the coaxial cable to the receiver card prior to attaching to the Dev Board or Interposer card.

External Oscillator

Some applications require greater precision than that possible with the OEM7 VCTCXO, in which case you may need to connect the OEM7 to an external high-stability oscillator, which may run at either 5 MHz or 10 MHz.

Antenna Selection

Select a quality GNSS antenna, such as one from NovAtel's 500 or 700 series. Contact your NovAtel representative or visit our web site www.novatel.com/products/gnss-antennas for a full range of available antenna options.

Mounting the Coaxial Cable into Bracket

The bracket openings are used to mount and secure the Antenna (ANT) and/or External Oscillator (OSC) connectors to the Development Board.

1. Remove the top nut and washer from the TNC/BNC end of the coaxial cable. Set aside.
2. Thread the TNC or BNC end of coaxial cable through the bracket from Dev Board side to the outside (either opening).
3. Slide the washer and then the nut over the TNC or BNC end of the protruding coaxial cable and slide up against the external side of the bracket.
4. Hand tighten nut to secure the cable and connector to the bracket.
5. Connect antenna to receiver card or EVENT to the Dev Board.
6. Continue to **Installation & Powering Steps** section or repeat as needed for second cable.

When using standoffs with receiver cards or mounting directly to Dev Board, attach the MCX, MMCX or MMBX connector as required BEFORE securing the boards with the standoffs and screws.

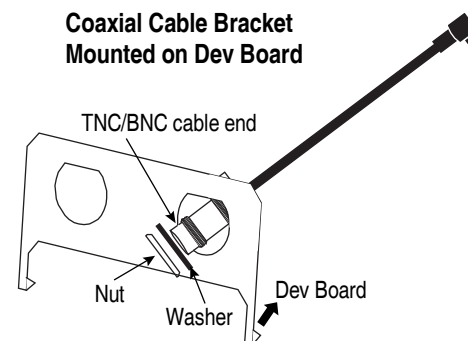

Warnings and Restrictions

For evaluation only, in Laboratory/Development Environments. The development kit is not finished electrical and electronic equipment (EEE) and is not intended for consumer use. It is intended solely for use for preliminary evaluation in laboratory/development environments by technically qualified experts who are familiar with the dangers and application risks associated with handling electrical mechanical components, systems, and subsystems. The development kit should not be used as all or part of a finished end product.

Federal Communications Commission (FCC) and Industry Canada (IC) Notices:

This development kit is designed to allow:

- (1) Product developers to evaluate electronic components, circuitry, or software associated with the kit to determine whether to incorporate such items in a finished product and
- (2) Software developers to write software applications for use with the end product. This kit is not a finished product and when assembled may not be resold or otherwise marketed unless all required FCC and IC equipment authorizations are first obtained. Operation is subject to the condition that this product not cause harmful interference to licensed radio stations and that this product accept harmful interference.
- (3) This kit generates, uses, and can radiate energy and has not been tested for compliance with the limits of digital devices pursuant to Part 15 of FCC or ICES-003 rules which are designed to provide reasonable protection against radio frequency interference.

EU Declaration of Conformity

Hereby, NovAtel Inc. declares that the OEM7 Development Kit is in compliance with Directive 2011/65/EU. The full text of the EU declaration of conformity is available at the following internet address: www.novatel.com/products/compliance.

Status LED States

Left LED Stack from Top			Right LED Stack from Top		
LED#	Description	Color	LED#	Description	Color
6	n/a		7	n/a	
4	Status	GREEN*	5	POS_VALID	GREEN
2	Status	RED*	3	ME_RDY	GREEN
0	ERROR	RED	1	POWER	GREEN

* LED 2 and 4 represents the receiver card's onboard LED status (when on at the same time, they represent the yellow error status code). Search for *Status Indicator* in the OEM7 online documentation.

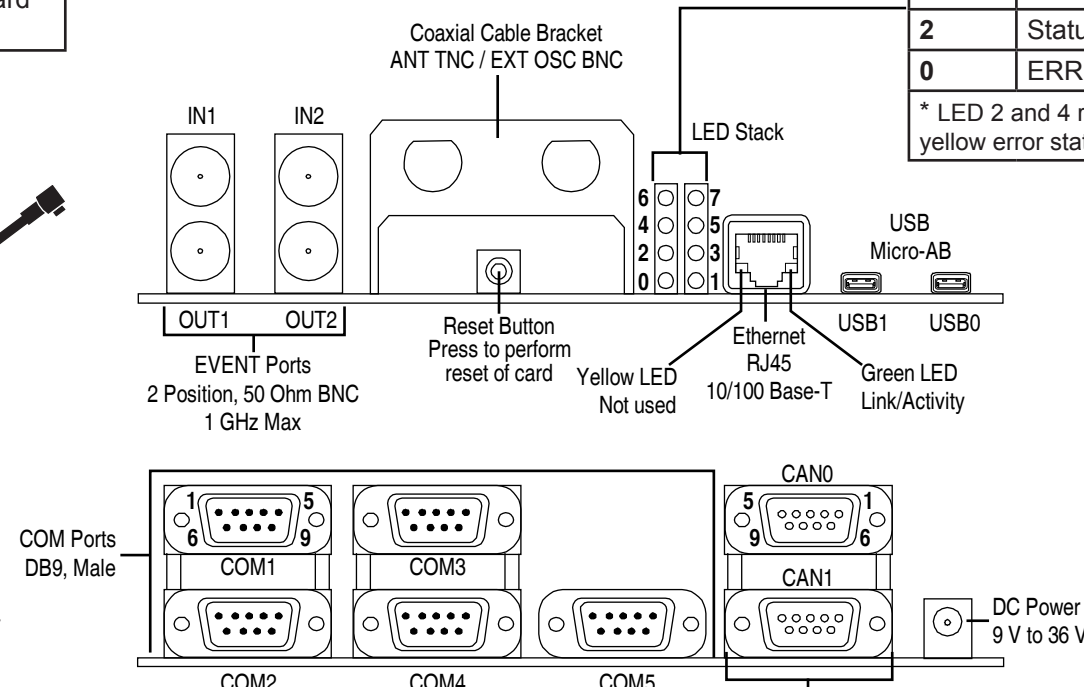

PIN#	COM1	COM2 ¹	COM3, COM4, COM5
1	NC	NC	NC
2	RXD1	RXD2	RXD
3	TXD1	TXD2	TXD
4	NC	NC	NC
5	GND	GND	GND
6	NC	NC	NC
7	RTS1	RTS2	NC
8	CTS1	CTS2	NC
9	NC	NC	NC

¹ COM2 RTS/CTS MUX with COM5 TXD/RXD

PIN#	CAN0	CAN1
1	NC	NC
2	CAN_L	CAN_L
3	GND	GND
4	NC	NC
5	GND	GND
6	GND	GND
7	CAN_H	CAN_H
8	NC	NC
9	12 V CAN power	12 V CAN power

Installation & Powering Steps

1. Flip the Dev Board upside down. Attach the four provided rubber feet over the four white circles in each corner of the the Dev Board. These provide stability for the board.
2. Turn the Dev Board right side up and place on a flat stable surface.
3. Ensure the steps listed in the **Mounting the Coaxial Cable into Bracket** section are complete before progressing to Step 4.
4. If using, make the connections/attachments for the ANT/OSC cables using the TNC/BNC end of the coaxial cable and connect to receiver card or Dev Board as indicated in **Coaxial Cable Assembly** table.
5. If needed, attach the Interposer card to the Dev Board using the provided standoffs and screws as indicated in the **Standoff Use** table on the other side of this sheet.
6. If required, attach the applicable receiver card to the Interposer card using the provided standoffs and screws OR Attach applicable receiver card directly to the Dev Board using the provided standoffs and screws as indicated in the **Standoff Use** table on the other side of this sheet.
7. If using, connect EVENT end cable to applicable EVENT connector on the Dev Board. Refer to the **Coaxial Cable Assembly** table on this page. For event connector locations, refer to the illustration on the other side of this sheet.
8. Set external power supply to 9 V to 36 V.
9. Set any Slide Switches on the Dev Board and, if using, the Interposer card. Refer to the **Switch Settings** tables on the other side of this sheet.
10. Connect any communications equipment to be used.
11. Connect power cord and plug into external power supply.