

HC990EXF

Preliminary



HC990EXF Extended-Filter Embedded Full GNSS Helical Antenna + L-Band

Frequency Coverage: GPS/QZSS-L1/L2/L5, QZSS-L6, GLONASS-G1/G2/G3, Galileo-E1/E5a/E5b/E6, BeiDou-B1/B2/B2a/B3, NavIC-L5 + L-Band correction services

The HC990EXF embedded helical antenna is designed for precision positioning, covering the GPS/QZSS-L1/L2/L5, QZSS-L6, GLONASS-G1/G2/G3, Galileo-E1/E5a/E5b/E6, BeiDou-B1/B2/B2a/B3, and NavIC-L5 frequency bands, including the satellite-based augmentation system (SBAS) available in the region of operation [WAAS (North America), EGNOS (Europe), MSAS (Japan), or GAGAN (India)], as well as L-band correction services.

The patent-pending HC990EXF utilizes Tallysman's latest wideband helical element design. The antenna element provides 67 MHz of signal bandwidth supporting the entire upper GNSS band and L-Band corrections (1539 - 1606 MHz) and 136 MHz of the lower band signal bandwidth (1164 - 1300 MHz). The other key component of the antenna is the axial ratio, which is a measure of how well the antenna captures the broadcast Right Hand Circular Polarized (RHCP) signal and mitigates the reflected LHCP signals. The Tallysman HC990EXF has a high peak gain of 3dBi, full bandwidth and 0.5 dB axial ratio at zenith, enabling excellent multipath mitigation and a very precise phase centre.

Weighing only 15 g, the light and compact HC990E features a precision-tuned helix element that provides excellent axial ratios and operates without the requirement of a ground plane, making it ideal for a wide variety of applications, including unmanned aerial vehicles (UAVs).

The HC990EXF features an industry-leading low current, low-noise amplifier (LNA) that includes an integrated low-loss pre-filter to prevent harmonic interference from high-amplitude signals, such as 700 MHz band LTE and other near-band cellular signals. As the radio frequency spectrum has become more congested, the signals or harmonic frequencies of new LTE bands [e.g. 800MHz x 2 = 1600MHz (GLONASS-G1)] can affect GNSS antennas and receivers. In North America, planned Ligado signals at 1525 - 1536 MHz can especially impact GNSS antennas that support space-based L-band correction services (1539 - 1559 MHz). New LTE signals in Europe [Band 32 (1452 - 1496 MHz)] and Japan [Bands 11 and 21 (1476 - 1511 MHz)] have also been observed to interfere with GNSS signals. In addition, Inmarsat satellite communication (uplink: 1626.5 - 1660.5 MHz) can also affect GNSS signals. The new Tallysman XF antennas have been designed to mitigate out-of-band signals and prevent GNSS antenna saturation. Tallysman's custom XF filtering mitigates all existing signals and new Ligado and LTE signals, enabling the antennas and attached GNSS receivers to perform optimally.

Care must be taken in installing the HC990EXF as ground planes below the antenna can affect its tuning. To facilitate a successful installation and optimum antenna performance, Tallysman also provides an Embedded Helical Antenna Installation Guide. For mounting instructions, visit: https://www.tallysman.com/downloads/Helical_Mounting_Instruction.pdf



Mechanical Drawing

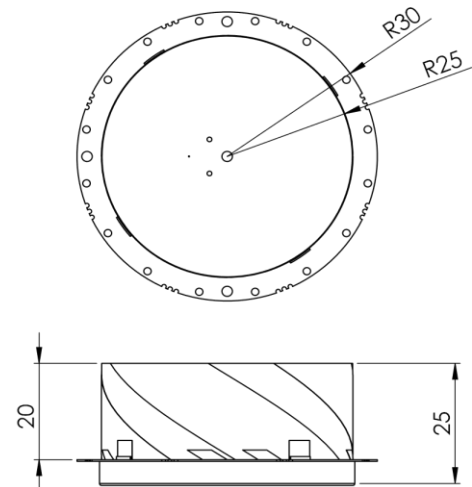

Applications

- Autonomous unmanned aerial vehicles (UAVs)
- Precision GNSS positioning
- Precision land survey positioning
- Mission-critical GNSS timing
- Network timing and synchronization
- Sea and land container tracking
- Fleet management and asset tracking
- Marine and avionics systems
- Law enforcement and public safety

Features

- Very low noise preamp (2.2 dB typ.)
- Axial ratio (≤ 0.5 dB at zenith)
- High LNA gain (35 dB typ.)
- Low current (35 mA typ.)
- ESD circuit protection (15 kV)
- Invariant performance from 2.2 to 16 VDC
- REACH, and RoHS compliant

Benefits

- Extremely light (12 g)
- Excellent RH circular polarized signal reception
- Great multipath rejection
- Increased system accuracy
- Excellent signal-to-noise ratio
- Industrial temperature range



Contact NavtechGPS for product details. www.NavtechGPS.com
+1-703-256-8900 • 800-628-0885 • info@navtechgps.com

HC990EXF Extended-Filter Embedded Full GNSS Helical Antenna + L-Band

Frequency Coverage:

GPS/QZSS-L1/L2/L5, QZSS-L6, GLONASS-G1/G2/G3, Galileo-E1/E5a/E5b/E6, BeiDou-B1/B2/B2a/B3, NavIC-L5
+ L-Band correction services

Antenna

Technology Full-spectrum, RHCP quadrifilar helix

| | | Gain | Axial Ratio |
|---------------------------------|-----|---------------------|--------------|
| | | dBic typ. at Zenith | dB at Zenith |
| GNSS | | | |
| GPS / QZSS | L1 | 2.5 | ≤ 0.5 |
| | L2 | 2.1 | ≤ 0.5 |
| | L5 | 1.6 | ≤ 0.5 |
| GLONASS | G1 | 2.3 | ≤ 0.5 |
| | G2 | 2.0 | ≤ 0.5 |
| | G3 | 2.4 | ≤ 0.5 |
| Galileo | E1 | 2.5 | ≤ 0.5 |
| | E5a | 1.6 | ≤ 0.5 |
| | E5b | 2.4 | ≤ 0.5 |
| | E6 | 2.0 | ≤ 0.5 |
| BeiDou | B1 | 2.5 | ≤ 0.5 |
| | B2 | 2.4 | ≤ 0.5 |
| | B2a | 1.6 | ≤ 0.5 |
| | B3 | 2.2 | ≤ 0.5 |
| IRNSS / NavIC | L5 | 1.6 | ≤ 0.5 |
| QZSS | L6 | 2.0 | ≤ 0.5 |
| L-band correction services | | 2.7 | ≤ 0.5 |
| Satellite Communications | | | |
| Iridium | | - | - |
| Globalstar | | - | - |
| Phase Centre | | | |
| Phase Centre Variation (PCV) | | TBD | |
| Phase Centre Offset (PCO) | | TBD | |

Mechanicals

| | |
|----------------------|-------------------------------|
| Mechanical Size | 60.0 mm (dia.) x 26.0 mm (h.) |
| Weight | 12 g |
| Available Connectors | Flying Lead (UFL) |
| Radome / Enclosure | - |
| Mount | Helical mounting ring P/N # |

Environmental

| | |
|-----------------------|--|
| Operating Temperature | -45 °C to +85 °C |
| Storage Temperature | -55 °C to +95 °C |
| Random Vibration | - |
| Shock and Drop | - |
| Salt Fog | - |
| IP Rating (housing) | n/a |
| Compliance | IPC-A-610, FCC, RED / CE Mark, RoHS, REACH |

Warranty:

| | |
|------------------|--------------------------|
| Parts and Labour | 1-year standard warranty |
|------------------|--------------------------|

Low Noise Amplifier (LNA) - Measured at 3.0 VDC and 25°C

| Frequency Bandwidth | Out-of-Band Rejection |
|-----------------------------|---|
| Lower Band | 1164 - 1300 MHz ≥ 85 dB @ ≤ 0950 MHz ≥ 70 dB @ ≤ 1125 MHz ≥ 75 dB @ ≥ 1350 MHz |
| L-band corrections services | 1539 - 1559 MHz ≥ 65 dB @ ≤ 1500 MHz ≥ 45 dB @ ≤ 1525 MHz ≥ 05 dB @ ≤ 1536 MHz ≥ 30 dB @ ≥ 1626 MHz ≥ 65 dB @ ≥ 1650 MHz |
| Upper Band | 1559 - 1606 MHz |

| | |
|------------------------|---------------------------|
| Architecture | Pre-filter → LNA |
| Gain | 35 dB typ. |
| Noise Figure | 2.0 dB typ. |
| VSWR | < 1.5:1 typ. 1.8:1 max. |
| Supply Voltage Range | 2.2 to 16 VDC |
| Supply Current | 36 mA typ. |
| ESD Circuit Protection | 15 kV air discharge |
| P 1dB Output | TBD |
| Group Delay Variation | TBD |

Installation Instructions

PROPER INSTALLATION

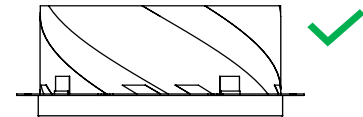

No metallic ground plane or PCB

IMPROPER INSTALLATION

(1) Antenna embedded in Metallic surface

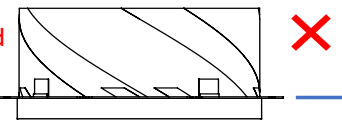

or

(2) Antenna sitting on metallic ground plane or PCB

Ordering Information

| | |
|-------------|--------------------|
| Part Number | 33-HC990EXF |
|-------------|--------------------|

Please refer to our **Ordering Guide** to review available radomes and connectors at:
<https://www.tallysman.com/resource/tallysman-ordering-guide/>



Contact NavtechGPS for product details. www.NavtechGPS.com
+1-703-256-8900 • 800-628-0885 • info@navtechgps.com