

LabSat 3 Wideband is a stand-alone RF signal record and replay system with three independently tuneable wideband channels. This allows for the record and replay of most GNSS signals and even a few non-GNSS signals. The three RF channels all share a common sample rate which can be adjusted from 10MHz up to 58MHz. All systems use an OCXO for maximum stability.

Quantisation of I and Q signals is selectable from 1, 2 or 3 bits per signal. Depending on the combination of channel bandwidth and quantisation, **LabSat 3 Wideband** will adjust the number of available RF channels to keep the record data bandwidth within a rate that ensures continuous data transfer.

Because wideband recording allows for the capture of multiple GNSS frequencies within each RF channel, **LabSat 3 Wideband** is configured by selecting the frequency bands most suitable for the capture of the required GNSS signals. To aid selection, **LabSat 3 Wideband** will display only the frequencies appropriate to capture GNSS signals for the selected bandwidth and will indicate which GNSS signals are within the selected band. During recording or replay, an in-built multi-constellation GNSS receiver gives details of satellites in view via the LCD display and will output NMEA data via USB.



In addition to the replay of live sky recorded signals, the optional **SatGen** software package can be used to generate simulated satellite signals from a user defined trajectory, allowing tests to be carried out simulating any time, date or place anywhere in the world.



Features

- Wide bandwidth - record up to 56MHz per channel
- Compact, lightweight and portable
- Fully standalone
- Battery life > 2 hours
- Simple to use one touch recording
- GPS L1, L2, L5
- GLONASS L1, L2, L3
- Galileo E1, E5a/b, E6
- BeiDou B1, B2, B3
- QZSS L1, L2
- NavIC L5 & S-Band

LabSat 3 Wideband supports a number of powerful features for use in industries such as automotive, aerospace and high accuracy RTK survey and vehicle control. It includes up to three RF channels for multiple constellation testing and support for RS232 recording, dual CAN bus recording, digital event capture and inertial sensor logging.

Part Number	Description	Constellations	GNSS Antenna
RLLS03W-RP	LabSat 3 Wideband Record and Replay	GPS: L1/L2/L5 GLONASS: L1/L2/L3 BeiDou: B1/B2/B3 QZSS: L1/L2/L5 Galileo: E1/E1a/E5a/E5b/E6 NavIC: L5 & S-Band SBAS: WAAS, EGNOS, GAGAN, MSAS, SDCM	RLACS249 Wideband GNSS magnetic antenna with SMA connector (3 meter cable)
RLLS03W-P	LabSat 3 Wideband Replay Only	GPS: L1/L2/L5 GLONASS: L1/L2/L3 BeiDou: B1/B2/B3 QZSS: L1/L2/L5 Galileo: E1/E1a/E5a/E5b/E6 NavIC: L5 & S-Band SBAS: WAAS, EGNOS, GAGAN, MSAS, SDCM	Includes LabSat carry case and the Expansion connector

Theory of Operation

The **LabSat 3 Wideband** contains a number of record and replay blocks and a high accuracy clock generator all controlled by a CPU and FPGA.

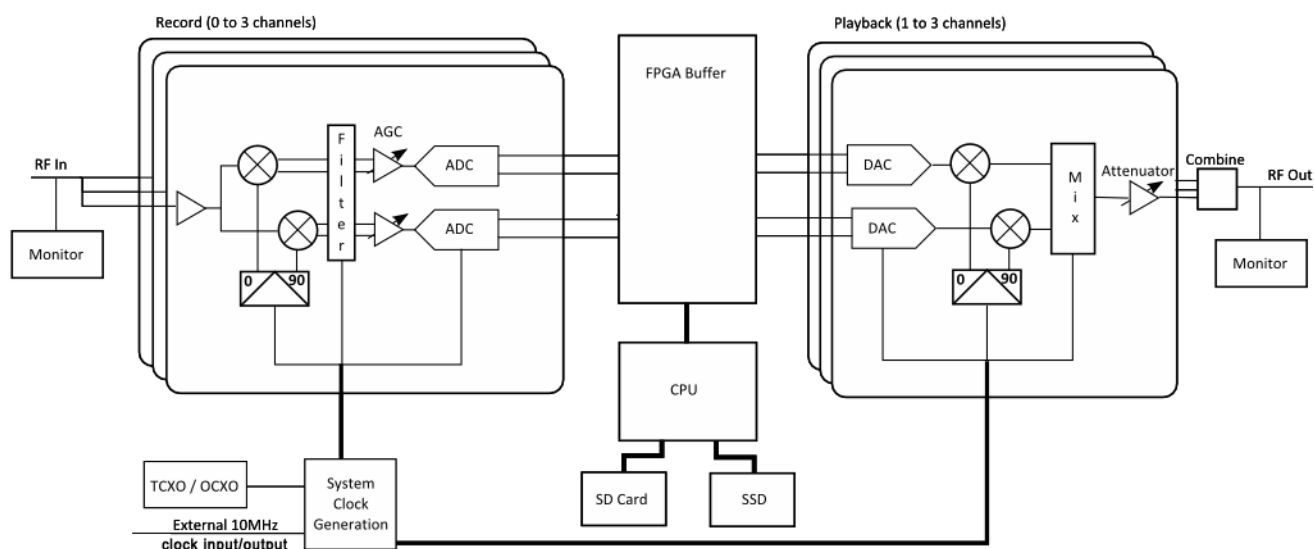

Clock Generation

In order to ensure synchronisation all critical system clocks are generated from a single low noise clock synthesiser. This system takes its reference input from either the internal TCXO, OCXO or the external clock input port, and generates all of the required clock frequencies within the **LabSat 3 Wideband**.

Record

Record and replay versions of the **LabSat 3 Wideband** feature 3 record blocks. Each of these blocks can be set to 1, 2 or 3 bit quantisation and the RF input is split between all of the record blocks within a unit.

Each record block features the following stages:

- An LNA (Low Noise Amplifier) with a gain of 8dB
- A local oscillator that generates the required signal centre frequency
- A quadrature mixer that converts the RF input into baseband I and Q signals

Each of the I and Q signals are then passed through:

- A low pass baseband filter
- An automatic gain control (AGC) with a dynamic range of 72dB operating over a period of between 16 and 256 samples
- A 3 bit ADC with a variable sample rate of up to 58MHz

The resulting I and Q samples are buffered within an FPGA before being passed to the system CPU for storage on the internal SSD.

The centre frequency for each record channel can be set independently allowing any channel to capture a range of GNSS frequencies with variable bandwidth and bit levels depending upon the requirement.

Replay

LabSat 3 Wideband features 3 replay blocks. Each playback block will automatically be set to 1, 2 or 3 bit quantisation in order to match the recorded signals.

During playback I and Q data is read from the storage media and buffered into the FGPA. The FPGA then passes these samples to the playback blocks at the required rate.

Each playback block features the following stages:

- Twin DACs running at up to 58MHz which convert the I and Q data into analogue signals
- A local oscillator that generates the required signal centre frequency
- A quadrature modulator that combines the I and Q signals into a single signal at the required frequency
- A variable attenuator giving between +20dB and -69dB of adjustment

The outputs from each of the playback stages are then combined, filtered and further attenuated to bring the signal levels to the high end of the range normally expected for GNSS signals.

Finally the resulting signal is split between the RF Out port on the **LabSat 3 Wideband** and an internal L1 GNSS receiver used for monitoring the signals.

Custom test scenarios with SatGen

If you want to create your own custom test scenario using artificial signals, **SatGen** software allows you to quickly draw a route using Google maps, and then automatically creates an RF file which can then be transferred from the PC to the SSD memory via Ethernet and replayed on the **LabSat 3 Wideband**.

A 30 day **SatGen** demo version, limited to 2 minute scenarios, is available for download on the **LabSat** website. Please contact your local **LabSat** distributor for **LabSat & SatGen** packages.

Usage Considerations

Recording

As with any electronic equipment the **LabSat 3 Wideband** outputs a small amount of unintentional RF energy. Due to the weak nature of GNSS signals it is recommended that any electrical equipment including the **LabSat 3 Wideband** should be placed as far away from any GNSS antennas as possible and kept below the level of the antennas ground plane.

Signal Levels

As shown above the record path includes an AGC stage. Due to the wide range of possible input signal levels this is required to maintain the incoming signals at a level suitable for digitisation. This process has no impact on the SNR levels of the recorded signals since both the GNSS signal and the noise are amplified equally. However due to this normalisation of the input signal the RF signal strength of the output will be constant for a set attenuation level and will not accurately reflect the absolute signal level recorded.

Signal SNR's

Ideally the SNR of a recorded and replayed GNSS signal will be the same as was seen when observing the live signal since both the signal and the in-band noise are recorded and replayed. Unfortunately, due to the quantising nature of record and replay systems there will inevitably be a slight drop in observed signal strengths.

Webserver

LabSat 3 Wideband has a complex array of settings for both GNSS signal and external data recording. To simplify the configuration and device control process, LabSat 3 Wideband has an internal webserver for configuration which can be easily accessed via a standard PC internet web browser.

When LabSat 3 Wideband has an IP address, the web server can be opened by entering the IP address into a web browser, Racelogic advise using Internet Explorer, Firefox or Google Chrome.

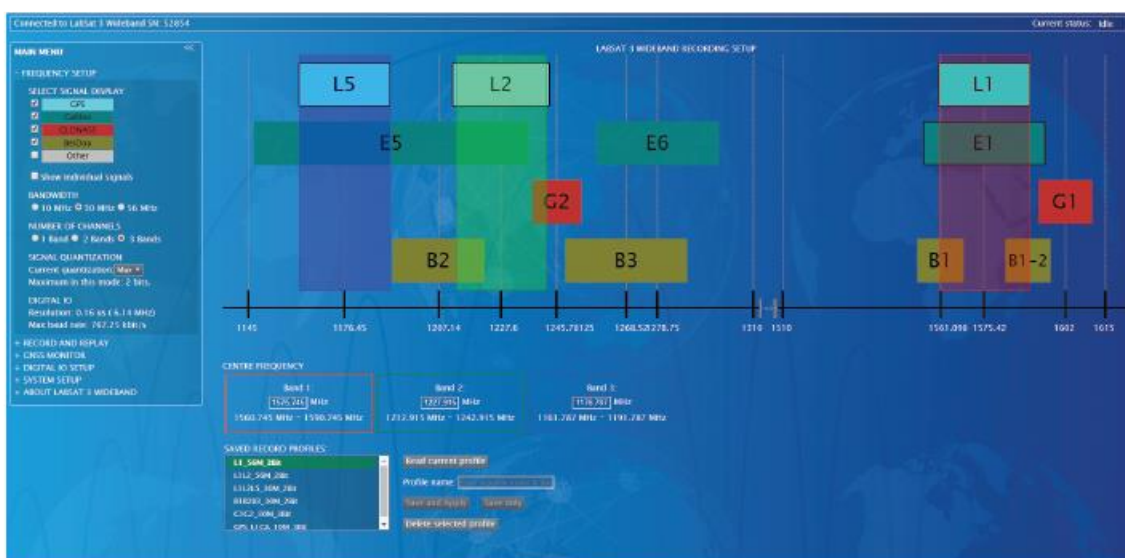

Technical Specifications

	LabSat 3 Wideband	
Constellations	GPS L1, L2, L5; Galileo E1, E5a/b, E6; GLONASS L1, L2, L3; BeiDou B1, B2, B3; QZSS L1, L2, L5; NavIC L5 & S-Band; In Band SBAS Further signals in the upper and lower L band can be configured with the internal webserver. Bespoke requirements like Iridium & Sirius XM radio frequencies are available on request.	
Nominal Output Signal Level	-73dBm/MHz @ 0dB Variable attenuator provides between +20 dB and -69 dB of adjustment during replay	
RF Channels	3	
RF Channel 1 Centre Frequency	Selectable	
RF Channel 2 Centre Frequency	Selectable	
RF Channel 3 Centre Frequency	Selectable	
Number of Satellites Observed	All in view	
Sampling Frequency	10.23MHz, 30.69MHz, 58MHz	
Bandwidth	10MHz, 30MHz, 56MHz	
Quantisation	1, 2 or 3 bit (I & Q)	
Data Format	I & Q	
Additional Logging	2x CAN channels, 4x Digital channels	
Removable Battery Pack	Yes	
Media Storage Included	1TB SSD & 8GB SD card (SD card for firmware upgrade only)	
Active Antenna Voltage Supply	2.8 – 4.6 v	
Reference Oscillator	TCXO Temperature Stability +/- 0.05 ppm Frequency Stability +/- 1 ppm over first year	OCXO Temperature Stability +/- 0.05 ppm Frequency Stability +/- 0.3 ppm over first year
Operating Voltage	8V to 30 VDC	
Size	167 mm x 128 mm x 46 mm	
Weight	1.2 kg	

Dimensions

The **LabSat 3 Wideband** dimensions in millimetres.

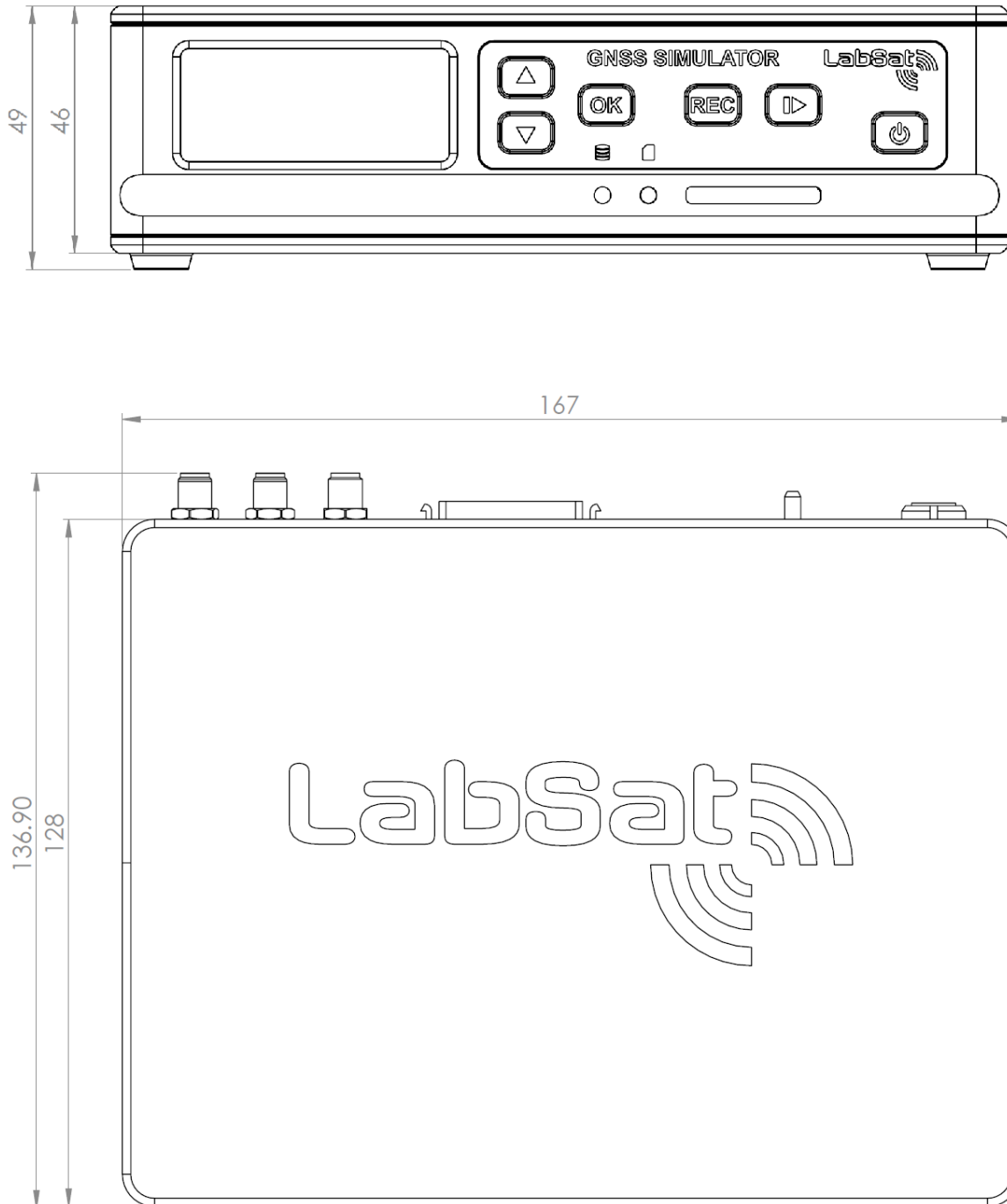

Connections

	Connection	Description
Power	2 pin LEMO	8 to 30V DC Power supply input
Host USB	USB Type A	For connection to USB storage devices (Data transfer only)
Ethernet	RJ45	Remote access/control and file transfers (Contact Racelogic for details – support@racelogic.co.uk)
USB	USB Type B	NMEA Output (Requires PC drivers - http://www.labsat.co.uk/software)
RF Out	SMA	Output for RF signal replay for connection to Device Under Test (DUT)
RF In	SMA	RF signal input from antenna
REF In	SMA	10MHz Reference Clock Input / Output
Expansion	36 WAY MDR	1-PPS, NMEA, Digital I/O, CAN Bus, RS232

Expansion port 36 way MDR type connector

The Expansion Connector on the rear of **LabSat 3 Wideband** gives access to a number of signals including CAN Bus, RS232, 1PPS & Digital input/output. Accessory RLACS202 is used to provide user signal access for integration into the users test system. Pin functions are described in the user manual.

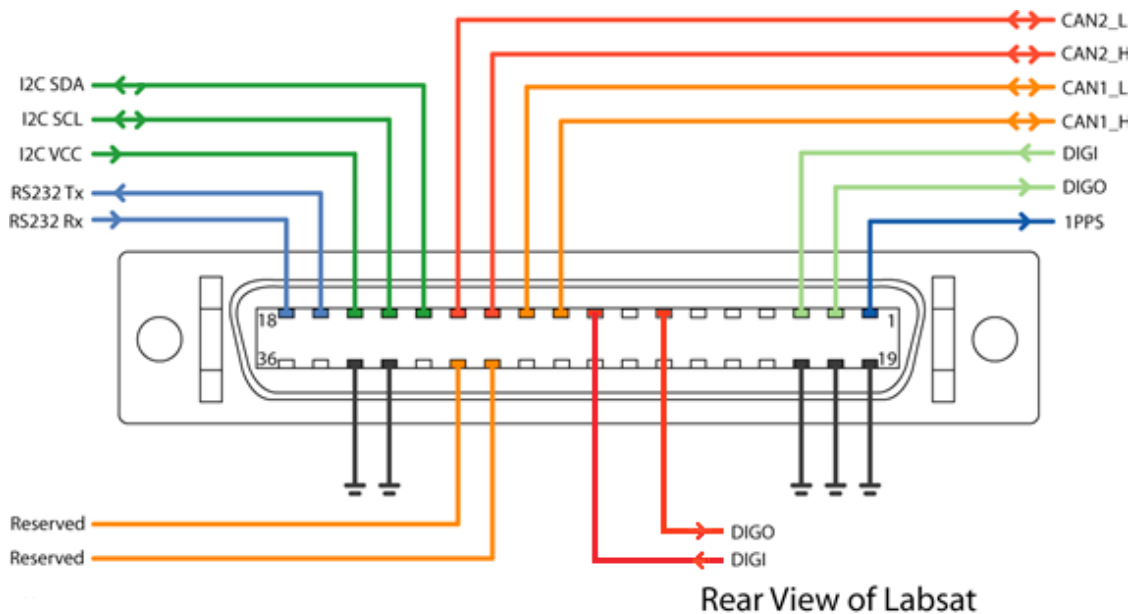

Description	Part Number
LabSat 3 Wideband unit	
Carry Case	RLACS197
Mains power supply - LEMO 2 W plug	RLVBACS020
8GB SD Card	LS03SDCARD-W
2 way LEMO to 12 V cigar lighter lead - 2m	RLCAB010LE
Wideband GNSS Magnetic Antenna with SMA Connector - 3m	RLACS249
SMA-SMA cable - 1m	RLCAB071-1
SMA plug to MCX plug cable - 1m	RLCAB082-1
SMA plug to MMCX plug cable - 1m	RLCAB083-1
SMA plug to TNC plug cable - 1m	RLCAB084-1
LabSat 3 Wideband Battery	RLACS229
Expansion connector adapter (inc. screwdriver)	RLACS202
Nano USB Wifi Dongle	RLACS271
USB to SATA cable	RLACS289
LabSat 3 Wideband Manual	Available online
Cable Identification Sheet	LS03W-CABIDEN
LabSat 3 Wideband Quick Start Guide	LS03WGUIDE

Optional Accessories

Description	Part Number
LabSat 3 Wideband 1TB SSD	LS03WSSD-1TB
LabSat 3 Wideband dipole antenna	RLACS219
USB 3.0 dual slot card reader	RLACS163
Wideband GNSS Passive Antenna	RLACS278
LabSat 3 Wideband Worldwide Scenario Library (2TB)	RLACS275
LabSat 3 Locking Expansion Connector	RLACS261