

TW3740



+1-703-256-8900 or 800-628-0885
info@NavtechGPS.com
www.NavtechGPS.com



CALIAN®

Confidence. Engineered.

High Gain Multi-Constellation Antenna

Frequency Coverage: GPS & QZSS L1 | GALILEO E1 | BEIDOU B1 | GLONASS G1

The TW3740 is a precision high-gain GNSS antenna covering the BeiDou B1, Galileo E1, GPS-L1, GLONASS-G1 and SBAS (WAAS, EGNOS, QZSS & MSAS) frequency band (1559 to 1606 MHz).

It employs Calian's patented Accutenna® technology providing truly circular polarized signal reception through the entire bandwidth of the antenna, thereby providing superior multipath signal rejection. It is especially designed for precision timing, industrial, agricultural, military, and other precision applications.

The TW3740 features a three stage low-noise amplifier, comprised of one input LNA per feed, a mid section SAW to filter the combined output, and a final output gain stage.

The TW3740 is housed in a permanent-mount metal base with two nickel coated nuts and a weatherproof enclosure. Two options for mounting are available: an L-bracket (P/N# 23-0040-0) or a pipe mount (P/N# 23-0065-0).



Applications

- High-accuracy & mission-critical global positioning
- Timing applications
- Precision agriculture, mining, and construction
- Law enforcement and public safety
- Avionics
- Law enforcement and public safety
- Fleet management and asset tracking

Features

- Accutenna® technology
- Great axial ratio: 1 dB typ.
- Low noise LNA: 1 dB
- High-rejection SAW filter
- High-gain LNA: 42 dB typ.
- Low current: 20 mA typ.
- Wide voltage input range (2.5 to 16 VDC)
- IP69K weatherproof housing

Benefits

- Circular polarisation throughout the full bandwidth
- Superior multipath signal rejection
- Excellent signal-to-noise ratio
- Great out-of-band signal rejection
- Increased system accuracy
- Ideal for harsh environments
- CE RED, RoHS, and REACH compliant



Contact NavtechGPS for product details. www.NavtechGPS.com
+1-703-256-8900 • 800-628-0885 • info@navtechgps.com

High Gain Multi-Constellation Antenna

Frequency Coverage: GPS & QZSS L1 | GALILEO E1 | BEIDOU B1 | GLONASS G1

Antenna - Measured with a 100 mm ground plane

Technology Dual-feed RHCP ceramic patch

		Gain	Axial Ratio
		dBic typ. at Zenith	dB at Zenith
GNSS			
GPS / QZSS	L1	4.3	≤ 2
	L2	-	-
	L5	-	-
GLONASS	G1	4.3	≤ 2
	G2	-	-
	G3	-	-
Galileo	E1	4.3	≤ 2
	E5A	-	-
	E5B	-	-
	E6	-	-
BeiDou	B1	4.3	≤ 2
	B2b	-	-
	B2a	-	-
	B3	-	-
IRNSS / NavIC	L5	-	-
QZSS	L6	-	-
L-Band Services (1539 MHz - 1559 MHz)		-	-
Satellite Communications			
Iridium	-	-	-
Globalstar	-	-	-
Other			
Axial Ratio at 10°	-	Efficiency	-
PCV Φ > 15°	-	PCO	-

Mechanicals

Size	66.5 mm (dia.) x 21 mm (h.)
Weight	150 g
Radome	LEXAN™ EXL9330, Base: Zamac Metal
Mount	Through-hole (100 mm ground plane provided)
Available Connectors	Please refer to ordering guide

Environmental

Operating Temperature	-40 °C to +85 °C
Storage Temperature	-55 °C to +95 °C
Vibration	MIL-STD-810-E - Test Method 514.5
Shock	MIL-STD-810-G - Test Method 516.6
Salt Fog	MIL-STD-810-F - Test Method 509.5
Other Tests	Hail, Humidity, Dust, Rain, Sand, Solar
IP Rating	IP69K
Compliance	IPC-A-610, FCC, CE RED, RoHS, REACH

Warranty

Parts and Labour	3-year standard warranty
------------------	--------------------------

Low Noise Amplifier (LNA) - Measured at 3V and 25°C

Frequency Bandwidth	Out of Band Rejection
Lower Band	-
L-Band Corr.	-
Upper Band	1559-1606 MHz
> 32 dB @ < 1500 MHz > 35 dB @ > 1640 MHz	

Architecture	Non pre-filtered
Gain	42 dB typ., 40 dB min.
Noise Figure	1 dB typ.
VSWR	< 1.5:1 typ., 1.8:1 max.
Supply Voltage Range	2.5 to 16 VDC nominal, up to 50 mV p-p ripple
Supply Current	20 mA typ.
ESD Circuit Protection	15 kV air discharge
P 1dB Output	-
Group Delay	-

Mechanical Diagram - Units in 'mm' or 'inches' where specified

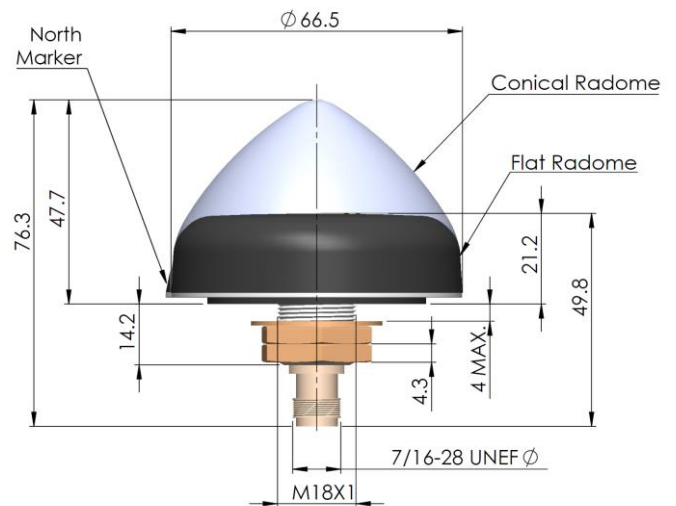

Ordering Information

Part Number **33-3740-xx-yy-zzzz**

Where xx = connector type, yy = shape and colour of radome and zzzz = cable length in mm (where applicable)

Please refer to our **Ordering Guide** to review available radomes and connectors at: <https://at.callan.com/gnss/information-support/part-number-ordering-guide/>



Contact NavtechGPS for product details. www.NavtechGPS.com
 +1-703-256-8900 • 800-628-0885 • info@navtechgps.com