

TW3967



+1-703-256-8900 or 800-628-0885
info@NavtechGPS.com
www.NavtechGPS.com



CALIAN[®]
Confidence. Engineered.

Embedded Multi-Constellation Triple-Band Antenna

Frequency Coverage: GPS L1, L2, L5 | GALILEO E1, E5a, E5b | BEIDOU B1, B2a, B2b | GLONASS G1, G2, G3 | NavIC L5 + L-Band

The TW3967 is an Accutenna® technology antenna providing triple-band GPS-L1/L2/L5, GLONASS-G1/G2/G3, BeiDou B1/B2, Galileo E1/E5 plus L-band Corrections coverage and is especially designed for precision triple frequency positioning. The TW3967 provides superior multipath signal rejection, a linear phase response, and tight phase centre variation (PCV). This antenna is ideal for precision agriculture, autonomous vehicle tracking and guidance, and other applications where precision matters.

The TW3967 features a precision tuned, twin circular dual-feed, stacked patch element. The signals from the two orthogonal feeds are combined in a hybrid combiner, amplified in a wideband LNA, then band-split for narrow filtering in each band and further amplified prior to recombination at the output.

The antenna also has a strong pre-filter to mitigate intermodulated signal interference from LTE and other cellular bands.

The TW3967 offers excellent axial ratio and a tightly grouped phase centre variation. The TW3967 covers from 1164 MHz to 1254 MHz and 1539 MHz to 1606 MHz.

The TW3967 is also available with 35 dB with part number TW3972E. A 100 mm ground plane is recommended.



Applications

- Precision GPS position
- Triple Frequency RTK receivers
- Mission Critical GPS Timing
- Law enforcement and public safety
- Network timing & synchronization

Features

- Very low noise preamp < 2.5 dB
- Axial ratio: < 2.0 dB typ.
- Tight phase centre variation
- High-gain LNA (28 dB typ.)
- Low current: 24 mA typ.
- ESD circuit protection (15 kV)
- Invariant performance from 2.5 to 16 VDC

Benefits

- Ideal for triple-band RTK surveying systems
- Great multipath rejection
- Increased system accuracy
- Great signal-to-noise ratio
- CE RED, RoHS, and REACH compliant

About Calian: With global headquarters and manufacturing in Ottawa, Canada, Calian is a leading manufacturer of high-precision antennas and components for Global Navigation Satellite System (GNSS) applications. Calian's mission is to support the needs of a new generation of positioning systems by delivering unprecedented antenna precision at competitive prices. Learn more at www.calian.com

Revision: 202407

Contact us:
info@tallysman.com
T: +1 613 591-3131

Embedded Multi-Constellation Triple-Band Antenna

Frequency Coverage: GPS L1, L2, L5 | GALILEO E1, E5a, E5b | BEIDOU B1, B2a, B2b | GLONASS G1, G2, G3 | NavIC L5 + L-Band

Antenna - Measured with a 100 mm ground plane

Technology Dual-feed Stacked RHCP ceramic patch

		Gain	Axial Ratio
		dBic typ. at Zenith	dB at Zenith
GNSS			
GPS / QZSS	L1	4.0	< 1
	L2	4.0	< 1
	L5	-1.5	< 1.5
GLONASS	G1	2.5	< 1.5
	G2	2.5	< 1.5
	G3	2.5	-
Galileo	E1	4.0	< 1
	E5A	-1.5	< 1.5
	E5B	2.5	< 1.5
	E6	-	-
BeiDou	B1	4.0	< 1
	B2b	2.5	< 1.5
	B2a	-1.5	< 1.5
	B3	-	-
IRNSS / NavIC	L5	-1.5	< 1.5
QZSS	L6	-	-
L-Band Services (1539 MHz - 1559 MHz)		3.5	< 1
Satellite Communications			
Iridium		-	-
Globalstar		-	-
Other			
Axial Ratio at 10°	-	Efficiency	-
PCV $\Phi > 15^\circ$	± 10 mm	PCO	-

Mechanicals

Size	62 mm (dia.) x 17 mm (h.) (see diagram)
Weight	70 g
Radome	-
Mount	5 x M2 screws
Available Connectors	Please refer to ordering guide

Environmental

Operating Temperature	-40 °C to +85 °C
Storage Temperature	-55 °C to +95 °C
Vibration	MIL-STD-810D Method 514.3-1
Shock	Vertical axis: 50 G, other axes: 30 G
Salt Fog	MIL-STD-810F Section 509.4
Other Tests	-
IP Rating	-
Compliance	IPC-A-610, FCC, CE RED, RoHS, REACH

Warranty

Parts and Labour	1-year standard warranty
------------------	--------------------------

Low Noise Amplifier (LNA) - Measured at 3V and 25°C

Frequency Bandwidth	Out of Band Rejection
Lower Band	1164 - 1254 MHz
L-Band Corr.	1539 - 1559 MHz
Upper Band	1559 - 1606 MHz

< 1050 MHz > 45 dB
< 1125 MHz > 30 dB
> 1350 MHz > 45 dB
< 1450 MHz > 30 dB
> 1690 MHz > 30 dB
> 1730 MHz > 40 dB

Architecture	Pre-filtered
Gain	28 dB typ.
Noise Figure	2.5 dB typ.
VSWR	< 1.5:1 typ., 1.8:1 max.
Supply Voltage Range	2.5 to 16 VDC nominal, up to 50mV p-p ripple
Supply Current	24 mA typ., 25 mA max. at 75 °C.
ESD Circuit Protection	15 kV air discharge
P 1dB Output	-
Group Delay	-

Mechanical Diagram - Units in 'mm' or 'inches' where specified

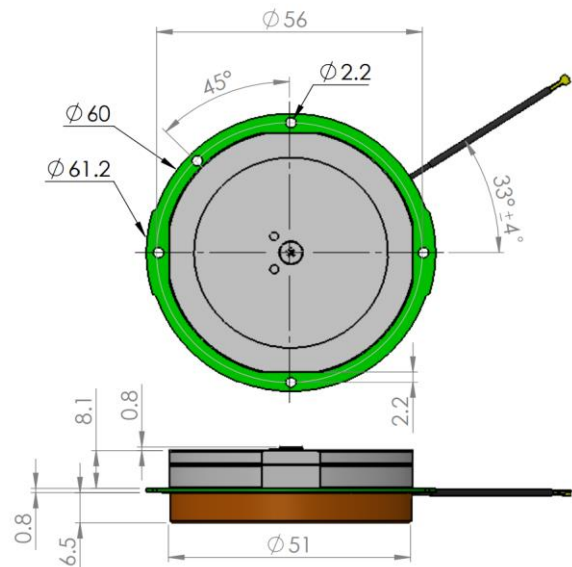

Ordering Information

Part Number **33-3967-xx-yy-zzzz**

Where xx = connector type, yy = shape and colour of radome and zzzz = cable length in mm (where applicable)

Please refer to our **Ordering Guide** to review available radomes and connectors at: <https://www.tallysman.com/resource/tallysman-ordering-guide/>



Contact NavtechGPS for product details. www.NavtechGPS.com
 +1-703-256-8900 • 800-628-0885 • info@navtechgps.com