

TW7875



+1-703-256-8900 or 800-628-0885
info@NavtechGPS.com
www.NavtechGPS.com



CALIAN[®]
Confidence. Engineered.

Multi-Constellation Dual-Band Antenna

Frequency Coverage: GPS L1, L5 | GALILEO E1, E5a | BEIDOU B1, B2a | GLONASS G1 | NavIC L5

The TW7875 is precision tuned dual-Band, Accutenna® technology antenna for reception of GPS-L1/L5, GLONASS-G1, BeiDou B1, Galileo E1/E5a, NavIC L5 and is especially designed for precision dual frequency positioning. The TW7875 provides superior multipath rejection and axial ratio, a linear phase response, and tight phase centre variation (PCV), while protecting against intermodulation and saturation caused by high-level cellular 700 MHz signals.

This antenna is ideal for precision agriculture, autonomous vehicle tracking and guidance, and other applications where precision matters. The TW7875 features a precision tuned, twin circular dual-feed, stacked patch element. The signals from the two orthogonal feeds are combined in a hybrid combiner, pre-filtered to minimize interference from out-of-band signals such as Cellular LTE then amplified in a wide-Band LNA and band-split for additional filtering and amplification stages prior to recombination at the output.

The TW7875 provides reception for signals in the bands 1165 MHz to 1189 MHz and 1559 MHz to 1606 MHz. It is housed in a magnetic mount, weatherproof enclosure. A 100 mm diameter ground plane is recommended for optimal antenna performance.



Applications

- Precision GPS position
- Dual Frequency RTK systems
- Mission Critical GPS Timing
- Safety & security

Features

- Very low noise preamp: < 2.5 dB
- Axial ratio: < 2.0 dB typ.
- Tight phase centre variation
- High-gain LNA: 32 dB typ.
- Low current: 24 mA typ.
- ESD circuit protection (15 kV)
- Invariant performance from 2.5 to 16 VDC

Benefits

- Ideal for dual-band RTK surveying systems
- Great multipath rejection
- Increased system accuracy
- Great signal-to-noise ratio
- IP67, REACH, RED, and RoHS compliant

About Calian: With global headquarters and manufacturing in Ottawa, Canada, Calian is a leading manufacturer of high-precision antennas and components for Global Navigation Satellite System (GNSS) applications. Calian's mission is to support the needs of a new generation of positioning systems by delivering unprecedented antenna precision at competitive prices. Learn more at www.calian.com

Contact us:
info@tallysman.com
T: +1 613 591-3131

Multi-Constellation Dual-Band Antenna

Frequency Coverage: GPS L1, L5 | GALILEO E1, E5a | BEIDOU B1, B2a | GLONASS G1 | NavIC L5

Antenna - Measured with a 100 mm ground plane

Technology Dual-feed Stacked RHCP ceramic patch

		Gain	Axial Ratio
		dBic typ. at Zenith	dB at Zenith
GNSS			
GPS / QZSS	L1	4.5	≤ 2
	L2	-	-
	L5	4.0	≤ 2
GLONASS	G1	4.0	≤ 2
	G2	-	-
	G3	-	-
Galileo	E1	4.0	≤ 2
	E5A	4.0	≤ 2
	E5B	-	-
	E6	-	-
BeiDou	B1	4.0	≤ 2
	B2b	-	-
	B2a	4.0	≤ 2
	B3	-	-
IRNSS / NavIC	L5	4.0	≤ 2
QZSS	L6	-	-
L-Band Services (1525 MHz - 1559 MHz)		-	-
Satellite Communications			
Iridium		-	-
Globalstar		-	-
Other			
Axial Ratio at 10°	-	Efficiency	-
PC Variation	± 10 mm	-	-

Mechanicals

Size	69 mm (dia.) x 22 mm (h.)
Weight	180 g
Radome	LEXAN™ EXL9330, Base: Zamac Metal
Mount	Magnetic
Available Connectors	See Ordering Guide

Environmental

Operating Temperature	-40 °C to +85 °C
Storage Temperature	-55 °C to +95 °C
Vibration	MIL-STD-810-E - Test Method 514.5
Shock	MIL-STD-810G Method 516.6
Salt Fog	MIL-STD-810-F - Test Method 509.5
IP Rating	IP67
Compliance	IPC-A-610, FCC, RED / CE Mark, RoHS, REACH

Warranty

Parts and Labour	3-year standard warranty
------------------	--------------------------

Low Noise Amplifier (LNA) - Measured at 3V and 25°C

Frequency Bandwidth		Out of Band Rejection
Lower Band	1164 - 1189 MHz	> 60 dB @ < 1040 MHz > 40 dB @ < 1120 MHz > 30 dB @ > 1225 MHz
L-Band Corr.	-	
Upper Band	1559 - 1606 MHz	> 40 dB @ < 1450 MHz > 30 dB @ < 1520 MHz > 35 dB @ < 1650 MHz

Architecture	Pre-filtered
Gain	32 dB typ.
Noise Figure	2.5 dB typ.
VSWR	< 1.5:1 typ., 1.8:1 max
Supply Voltage Range	2.5 to 16 VDC nominal, up to 50mV p-p ripple
Supply Current	24 mA typ., 25 mA max.
ESD Circuit Protection	15 kV air discharge
P 1dB Output	11 dBm typ.
Group Delay	-
PCO	-

Mechanical Diagram

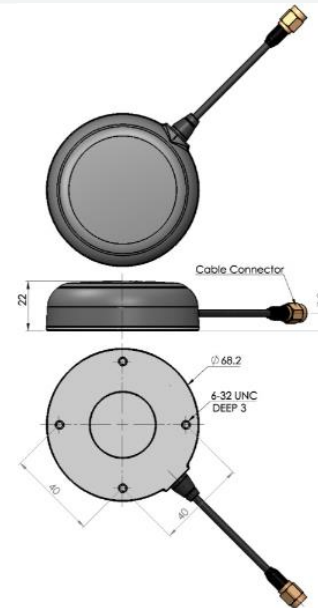

Ordering Information

Part Number **33-7875-xx-yyyy**

Where xx = connector type and yyyy = cable length in mm (where applicable)

Please refer to our **Ordering Guide** to review available radomes and connectors at:
<https://www.tallysman.com/resource/tallysman-ordering-guide/>



Contact NavtechGPS for product details. www.NavtechGPS.com
 +1-703-256-8900 • 800-628-0885 • info@navtechgps.com