

TW7972



+1-703-256-8900 or 800-628-0885
info@NavtechGPS.com
www.NavtechGPS.com



CALIAN[®]
Confidence. Engineered.

Multi-Constellation Triple-Band Antenna

Frequency Coverage: GPS L1, L2, L5 | GALILEO E1, E5a, E5b | BEIDOU B1, B2a, B2b | GLONASS G1, G2, G3 | NavIC L5 + L-Band

The TW7972 is a precision-tuned Accutenna® technology antenna supporting triple-band GPS/QZSS-L1/L2/L5, GLONASS-G1/G2/G3, Galileo-E1/E5a/E5b, BeiDou-B1/B2b/B2a, NavIC-L5, including the satellite-based augmentation system (SBAS) available in the region of operation [WAAS (North America), EGNOS (Europe), MSAS (Japan), or GAGAN (India)], plus L-Band correction services coverage, and is especially designed for precision triple-frequency positioning.

This antenna is ideal for precision agriculture, autonomous vehicle tracking and guidance, and other applications where precision matters.

The TW7972 features a dual-feed circular stacked patch element. The signals from the two orthogonal feeds are summed in quadrature, pre-filtered in a low loss filter to protect against a wide range of potentially interfering signals, amplified in high linearity, wideband LNA, then band-split, tightly filtered and amplified prior to signal recombination at the output.

This antenna provides superior multipath rejection and axial ratio, a linear phase response, and tight phase centre variation (PCV), while protecting against intermodulation and saturation caused by high-level LTE 700 MHz signals.

The TW7972 is housed in a magnetic mounted, IP67 weatherproof enclosure. A 100 mm diameter ground plane is recommended for optimal antenna performance.



Applications

- Autonomous vehicle tracking and guidance
- Positive Train Control (PTC)
- Positive Train Location (PTL)
- Precision GNSS positioning
- Precision agriculture
- Triple-frequency RTK and PPP receivers
- Law enforcement and public safety

Features

- Very low noise preamp (< 2.5 dB typ.)
- Low axial ratio (< 2.0 dB typ.)
- Tight phase centre variation
- High-gain LNA (32 dB typ.)
- Low current (24 mA typ.)
- ESD circuit protection (15 kV)
- Invariant performance from 2.5 to 16 VDC
- IP67, REACH, and RoHS compliant

Benefits

- Excellent multipath rejection
- Increased system accuracy
- Excellent signal-to-noise ratio

About Calian: With global headquarters and manufacturing in Ottawa, Canada, Calian is a leading manufacturer of high-precision antennas and components for Global Navigation Satellite System (GNSS) applications. Calian's mission is to support the needs of a new generation of positioning systems by delivering unprecedented antenna precision at competitive prices. Learn more at www.calian.com

Contact us:
info@tallysman.com
T: +1 613 591-3131

Multi-Constellation Triple-Band Antenna

Frequency Coverage: GPS L1, L2, L5 | GALILEO E1, E5a, E5b | BEIDOU B1, B2a, B2b | GLONASS G1, G2, G3 | NavIC L5 + L-Band

Antenna - Measured with a 100 mm ground plane

Technology Dual-feed Stacked RHCP ceramic patch

		Gain	Axial Ratio
		dBic typ. at Zenith	dB at Zenith
GNSS			
GPS / QZSS	L1	4.0	< 1.0
	L2	4.0	< 1.5
	L5	-1.5	< 2.0
GLONASS	G1	2.5	< 1.5
	G2	2.5	< 2.0
	G3	2.5	< 2.0
Galileo	E1	4.0	< 1.0
	E5A	-1.5	< 2.0
	E5B	2.5	< 2.0
	E6	-	-
BeiDou	B1	4.0	< 1.0
	B2b	2.5	< 1.5
	B2a	-1.5	< 2.0
	B3	-	-
IRNSS / NavIC	L5	-1.5	< 2.0
QZSS	L6	-	-
L-Band Services (1525 MHz - 1559 MHz)		3.5	< 1.0
Satellite Communications			
Iridium		-	-
Globalstar		-	-
Other			
Axial Ratio at 10°	-	Efficiency	-
PC Variation	± 10 mm	-	-

Mechanicals

Size	69 mm (dia.) x 22 mm (h.)
Weight	180 g
Radome	LEXAN™ EXL9330, Base: Zamac Metal
Mount	Magnetic
Available Connectors	See Ordering Guide

Environmental

Operating Temperature	-40 °C to +85 °C
Storage Temperature	-50 °C to 105 °C
Vibration	MIL-STD-810-E - Test Method 514.5
Shock	MIL-STD-810G Method 516.6
Salt Fog	MIL-STD-810-F - Test Method 509.5
IP Rating	IP67
Compliance	IPC-A-610, FCC, RED / CE Mark, RoHS, REACH

Warranty

Parts and Labour	3-year standard warranty
------------------	--------------------------

Low Noise Amplifier (LNA) - Measured at 3V and 25°C

Frequency Bandwidth	Out of Band Rejection
Lower Band	1164 - 1254 MHz
L-Band Corr.	1539 - 1559 MHz
Upper Band	1559 - 1606 MHz

≥ 45 dB @ ≤ 1050 MHz ≥ 30 dB @ ≤ 1125 MHz ≥ 35 dB @ ≥ 1350 MHz
≥ 30 dB @ ≤ 1450 MHz ≥ 30 dB @ ≥ 1690 MHz ≥ 40 dB @ ≥ 1730 MHz

Architecture	Pre-filtered
Gain	32 dB typ.
Noise Figure	2.5 dB typ.
VSWR	< 1.5:1 typ., 1.8:1 max
Supply Voltage Range	2.5 to 16 VDC nominal, up to 50mV p-p ripple
Supply Current	24 mA typ., 25 mA max.
ESD Circuit Protection	15 kV air discharge
P 1dB Output	11 dBm typ.
Group Delay	-
PCO	-

Mechanical Diagram

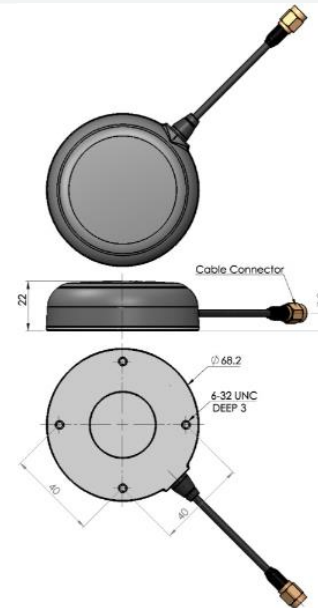

Ordering Information

Part Number **33-7972-xx-yyyy**

Where xx = connector type; yyyy = cable length in mm

Please refer to our **Ordering Guide** to review available radomes and connectors at: <https://www.tallysman.com/resource/tallysman-ordering-guide/>



Contact NavtechGPS for product details. www.NavtechGPS.com
 +1-703-256-8900 • 800-628-0885 • info@navtechgps.com