

VSP6337L-MAR



VSP6337L-MAR VeroStar™ Marine Triple-Band GNSS Precision Antenna + L-Band

Frequency Coverage: GPS/QZSS-L1/L2/L5, GLONASS-G1/G2/G3, Galileo-E1/E5a/E5b, BeiDou-B1/B2/B2a, NavIC-L5
+ L-Band correction services

The light and compact patent-pending VeroStar™ VSP6337L-MAR antenna is designed for high-accuracy positioning while being robust and reliable. This antenna employs Tallysman®'s unique VeroStar™ technology, providing high gain over the GPS/QZSS-L1/L2/L5, GLONASS-G1/G2/G3, Galileo-E1/E5a/E5b, BeiDou-B1/B2/B2a, and NavIC-L5 frequency bands, including the satellite-based augmentation system (SBAS) available in the region of operation [WAAS (North America), EGNOS (Europe), MSAS (Japan), or GAGAN (India)], as well as L-Band correction services.

With an exceptionally low roll-off from zenith to the horizon, each VeroStar antenna provides the best-in-class tracking of GNSS and L-Band correction signals from low elevation angles. In addition, the optimized axial ratio at all elevation angles results in excellent multipath rejection, thus enabling accurate and precise code and phase tracking of GNSS and L-band correction signals. Also, a wide-band spherical antenna element enables VeroStar antennas to deliver a ± 2 mm phase centre variation (PCV), making them ideal for high-precision applications, such as maritime positioning, autonomous vehicle navigation (land, sea, and air), and smart survey devices.

Each VeroStar antenna features a robust pre-filter and high-IP3 LNA architecture, minimizing de-sensing from high-level out-of-band signals, including 700 MHz LTE, while still providing a noise figure of only 1.8 dB. The VSP6337L-MAR antenna's filters also fully attenuate interference from Iridium and Inmarsat signals, providing 75 dB to 85 dB of attenuation over Iridium downlink (1616 - 1626 MHz) and 85 dB to 95 dB over Inmarsat uplink (1626 - 1660 MHz), making this antenna ideal for marine vessels.

The housed antenna, featuring an integrated rubber bumper to absorb routine impacts, has passed a battery of tests (water pressure, altitude, salt fog, shock, drop, and vibration) to ensure it can survive the rigours of day-to-day field use.

The unique features of the VeroStar antenna guarantee it can deliver a high signal-to-noise ratio (SNR) and highly accurate and precise code and phase tracking of GNSS signals from all elevation angles in the most challenging environments.



+1-703-256-8900 or 800-628-0885
info@NavtechGPS.com
www.NavtechGPS.com



Applications

- High-precision GNSS systems
- Marine navigation
- All embedded precision applications, such as:
 - Autonomous vehicle navigation (land, sea, air)
 - Deformation monitoring stations
 - Land survey rover
 - RTK/PPP systems
 - Reference networks

Features

- Tight phase centre variation (± 2 mm typ.)
- Low axial ratios from zenith to horizon
- Low roll-off from zenith to the horizon
- Superior low-elevation L-Band correction reception
- High G/T at low elevation angles
- Invariant performance from 3.0 to 16 VDC
- Low current (50 mA)
- Low noise figure (1.8 dB)
- Light, compact, and robust design
- IEC 60945, IEC 61108, IP69K, REACH, and RoHS compliant

Benefits

- Excellent mitigation of Iridium & Inmarsat interference
- Consistent performance across all frequency bands
- Excellent GNSS tracking from low elevation angles
- Extreme accuracy and precision
- Excellent multipath rejection



Contact NavtechGPS for product details. www.NavtechGPS.com
+1-703-256-8900 • 800-628-0885 • info@navtechgps.com

VSP6337L-MAR VeroStar™ Marine Triple-Band GNSS Precision Antenna + L-Band

Frequency Coverage: GPS/QZSS-L1/L2/L5, GLONASS-G1/G2/G3, Galileo-E1/E5a/E5b, BeiDou-B1/B2/B2a, NavIC-L5
+ L-Band correction services

Antenna			
Technology		Full GNSS frequency crossed dipoles	
		Gain	Axial Ratio
		dBic typ. at Zenith	dB at Zenith
GNSS			
GPS / QZSS	L1	4.0	< 1.0
	L2	4.5	< 1.0
	L5	4.0	< 1.0
GLONASS	G1	4.0	< 1.0
	G2	4.5	< 1.0
	G3	4.5	< 1.0
Galileo	E1	4.0	< 1.0
	E5a	4.0	< 1.0
	E5b	4.5	< 1.0
	E6	-	-
BeiDou	B1	4.0	< 1.0
	B2	4.5	< 1.0
	B2a	4.0	< 1.0
	B3	-	-
IRNSS / NavIC	L5	4.0	< 1.0
QZSS	L6	-	-
L-band correction services		4.0	< 1.0
Satellite Communications			
Iridium		-	-
Globalstar		-	-
Other			
Axial Ratio at 10°	5.0 dB max.	Efficiency	> 70%
Phase Centre Variation	± 2 mm typ. (no azi.)	G/T @10°C (L-band c.s.)	≥ -25.4 dB/K

Mechanicals	
Mechanical Size	170 mm (dia.) x 74.9 mm (h.)
Weight	500 g
Available Connectors	TNC (female)
Radome / Enclosure	EXL9330 plastic
Mount	5/8"-11 TPI or 1"-14 TPI

Environmental	
Operating Temperature	-45 °C to +85 °C
Storage Temperature	-55 °C to +95 °C
Mechanical Vibration	MIL-STD-810E - Test method 514.5
Shock and Drop	MIL-STD-810G - Test method 516.6
Salt Fog	MIL-STD-810G - Test method 509.6
Low Pressure - Altitude	MIL-STD-810F - Test method 500.5
IP Rating (housing)	IP69K
Compliance	IEC 60945, IEC 61108, IPC-A-610, FCC Part 15, RED / CE Mark, RoHS, REACH

Warranty:	
Parts and Labour	3-year standard warranty

Low Noise Amplifier (LNA) - Measured at 3.0 VDC and 25°C

Frequency Bandwith	Out-of-Band Rejection
Lower Band	1160 - 1300 MHz
L-band corrections services	1539 - 1559 MHz
Upper Band	1559 - 1606 MHz

≥ 90 dB @ ≤ 0900 MHz ≥ 70 dB @ ≤ 1000 MHz ≥ 30 dB @ ≤ 1090 MHz ≥ 60 dB @ ≥ 1410 MHz ≥ 70 dB @ ≥ 1430 MHz
≥ 65 dB @ ≤ 1510 MHz ≥ 75 dB @ ≥ 1616 MHz ≥ 85 dB @ ≥ 1626 MHz

Architecture	Pre-filter → LNA stage 1 → filter → LNA stage 2
Gain	37 dB min.
Noise Figure	1.8 dB typ. @ 25 °C
VSWR	< 1.5:1 typ. 1.8:1 max.
Supply Voltage Range	3.0 to 16 VDC nominal
Supply Current	50 mA typ.
ESD Circuit Protection	15 kV air discharge
P 1dB Output	+ 6.0 dBm
Group Delay Variation	< 10 ns

Mechanical Diagram

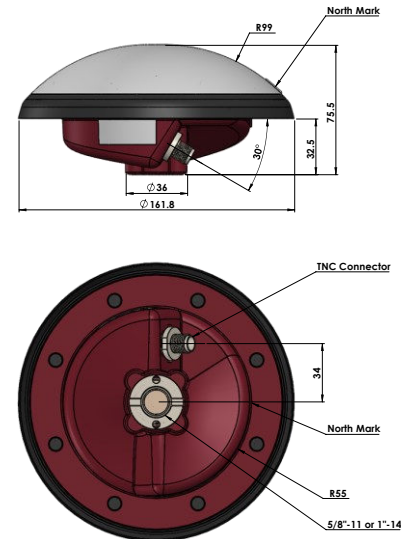

Ordering Information

Part Number **33-VSP6337L-MAR-zz**

where zz = mounting type: 58 = 5/8"-11 TPI | 01 = 1"-14 TPI

Please refer to our **Ordering Guide** to review available radomes and connectors at:
<https://www.tallysman.com/resource/tallysman-ordering-guide/>



Contact NavtechGPS for product details. www.NavtechGPS.com
+1-703-256-8900 • 800-628-0885 • info@navtechgps.com