



Trimble Zephyr 3 Base Antenna

PRECISION BASE ANTENNA WITH MILLIMETER ACCURACY

Integrated with Trimble Stealth™ ground plane to minimize multipath and protected by weather resisting materials, the top of the range Zephyr 3 Base antenna is the ideal antenna for control work.

COMPREHENSIVE GNSS SUPPORT

The Trimble Zephyr 3 Base antenna offers full support for current and near-future GNSS signals including GPS, GLONASS, Galileo, BeiDou, QZSS, IRNSS, OmniSTAR, Trimble RTX and SBAS.

TRIMBLE ZEPHYR 3 BASE

In addition to fixed base stations, the Zephyr 3 Base antenna is also suitable as a rover antenna for use in high multi-path environments. The Zephyr 3 Base antenna's quality performance and extreme accuracy are achieved through millimeter phase center repeatability, robust low-elevation tracking and reduced ground-based multipath interference.

Key Features:

- ▶ Additional Iridium filtering above 1616MHz allows antenna to be used as close as 20m of Iridium transmitter
- ▶ Additional filtering below 1510MHz allows for antenna placement closer to Japanese LTE cell tower
- ▶ Trimble Stealth Ground Plane – integrated lightweight stealth technology with enhanced right hand circular polarization to reduce multipath interference
- ▶ Advanced LNA (low noise amplifier) to reduce interference by high power out-of-band transmitters
- ▶ 50 dB signal gain for reliable tracking in challenging environments and long cable runs

Key Features

- ▶ Comprehensive GNSS support, including GPS Modernization signals, GLONASS, BeiDou and Galileo
- ▶ Robust low-elevation satellite tracking
- ▶ Large Trimble Stealth™ ground plane for multipath rejection
- ▶ Millimeter phase center repeatability
- ▶ Ideal for fixed reference stations and GNSS infrastructure networks
- ▶ Additional Iridium and Japanese LTE filtering
- ▶ High signal gain (50dB) for reliable tracking
- ▶ Low cross-sectional profile to reduce wind loading



Trimble Zephyr 3 Base Antenna

TECHNICAL SPECIFICATIONS

- Comprehensive GNSS Tracking:
 - GPS: L1, L2, L5
 - GLONASS: L1, L2, L3
 - BeiDou: B1, B2, B3
 - Galileo: E1, E5a, E5b, E6
 - QZSS: L1, L2, L5, LEX
 - IRNSS: L5
 - SBAS: WAAS, EGNOS, GAGAN, and MSAS
 - MSS: OmniSTAR, Trimble RTX
- Quality signal tracking, even at low elevations
- Four point antenna feed for phase center stability and enhanced polarization
- Powered by GNSS receiver via coaxial cable
- Optional transparent protection radome (available if desired)

ENVIRONMENTAL QUALIFICATIONS

Operating Temperature... -40 °C to +85 °C (-40 °F to +185 °F)
 Humidity... 100% humidity proof, fully sealed, IP67
 Shock and Vibration
 Tested and meets the following environmental standards:
 Shock: MIL-STD-810-F to survive a 2 m (6.56 ft) drop onto concrete
 Vibration: MIL-STD-810-F on each axis
 Compliance... CE compliant including ISO 13766:2006, 2014/45/EU (RED), EN 60950, E-Mark and RoHS, FCC, IC and RCM compliant

PHYSICAL AND ELECTRICAL SPECIFICATIONS

Dimensions... 34.3 cm diameter x 7.9 cm height (13.5 in diameter x 3.1 in height)
 Weight... 1.36 kg (3 lb)
 Input Voltage... 3.5 V DC to 20 V DC
 MSS Narrow Band Mode (1555 to 1559 MHz): >6.4 V DC to 9 V DC
 MSS Wide Band Mode (1525 to 1559 MHz): 3.5 V DC to 6.0 V DC and 9.4 V DC to 20 V DC
 Input Current... 125 mA
 Signal Gain... .50 dB
 Signal Connector... TNC Female
 Mounting... 5/8" - 11 Female Thread

PART NUMBERS

115000-50-INT... Zephyr Model 3 Base Antenna
 Specifications subject to change without notice

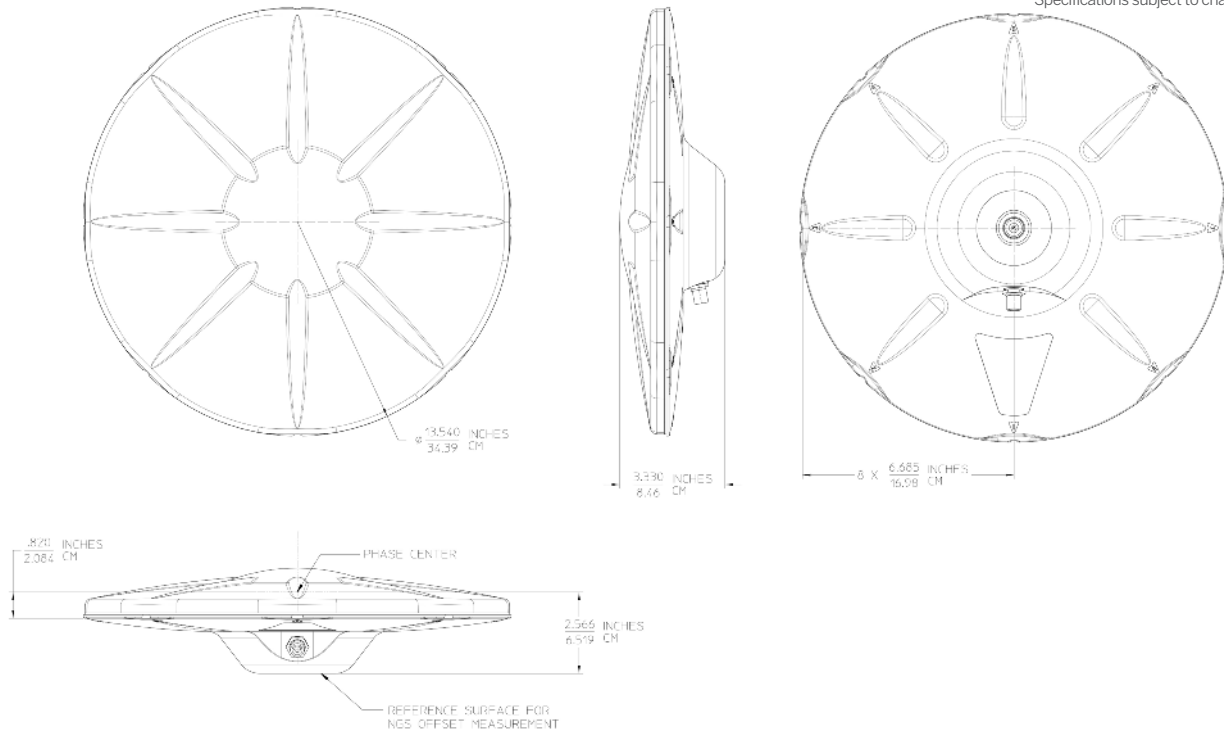

Contact us for product details and pricing

NavtechGPS

+1-703-256-8900 or 800-628-0885
 info@NavtechGPS.com
 www.NavtechGPS.com

TRIMBLE
 Integrated Technologies
 510 DeGuigne Drive
 Sunnyvale, CA 94085
 Americas & Asia-Pacific
 Europe/EMEA
 Email: sales-intech@trimble.com

© 2019, Trimble Navigation Limited. All rights reserved. Trimble logo are trademarks of Trimble, registered in the United States and in other countries. All other trademarks are the property of their respective owners. (08/19)